

Living with a *teenager* Higgs boson

(14 years with the Higgs boson, and the next 14 years)

A tale in 14 chapters

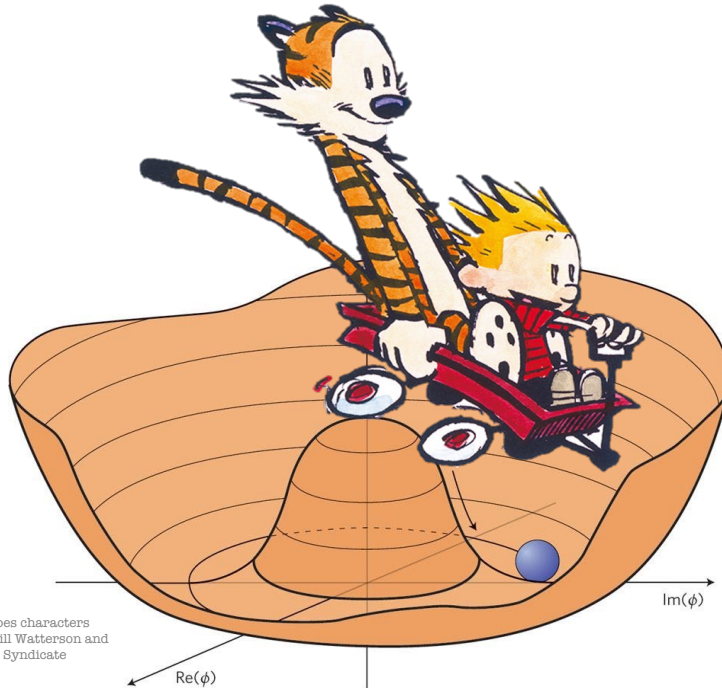

Calvin and Hobbes characters
copyright by Bill Watterson and
Universal Press Syndicate

Marco Delmastro

marco.delmastro@cern.ch

LAPP

Laboratoire d'Annecy de Physique des Particules

Università di Torino, 29/5/2026

Peter Higgs (29 May 1929 – 8 April 2024)

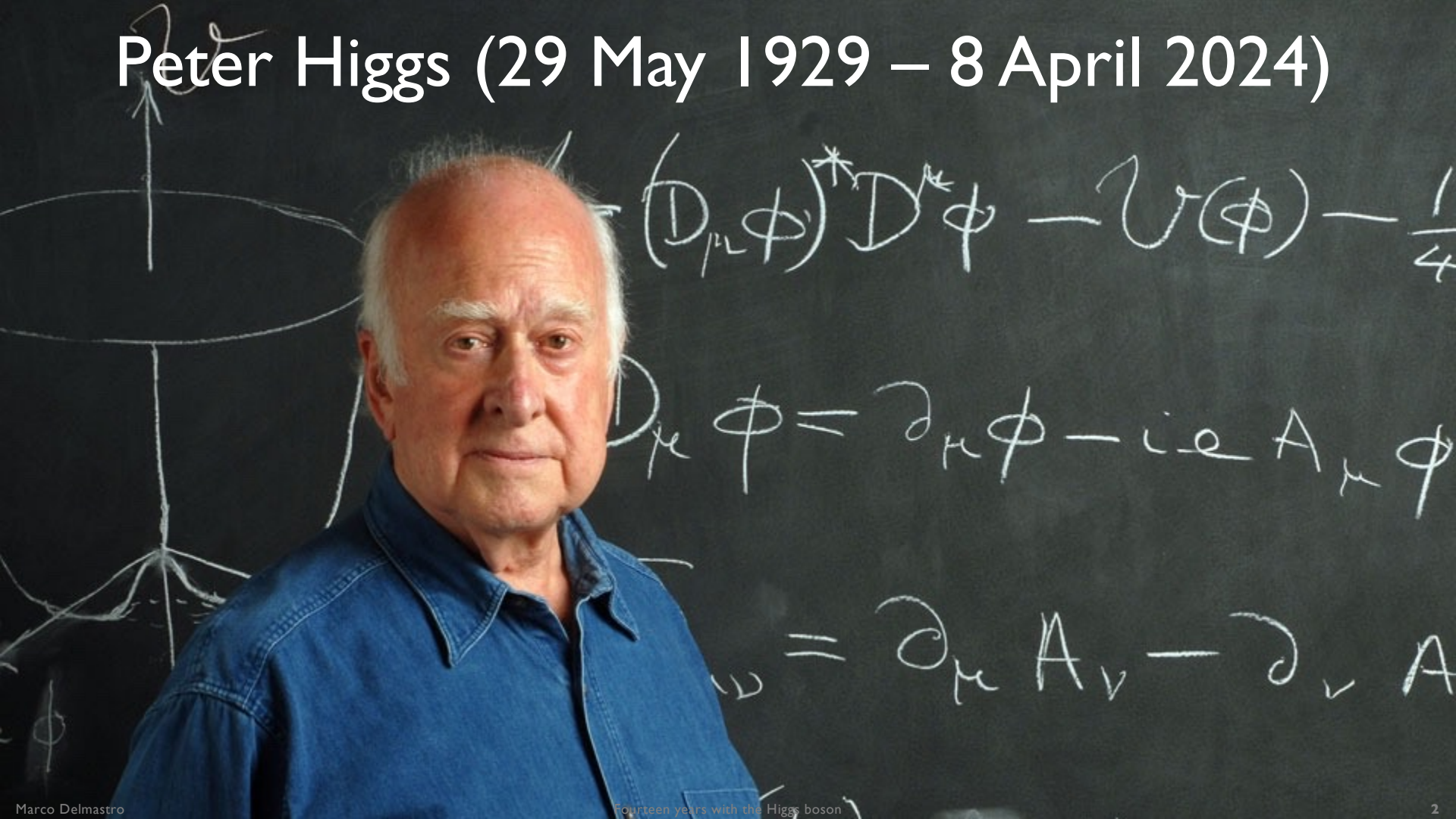

1.

Why the Higgs boson?

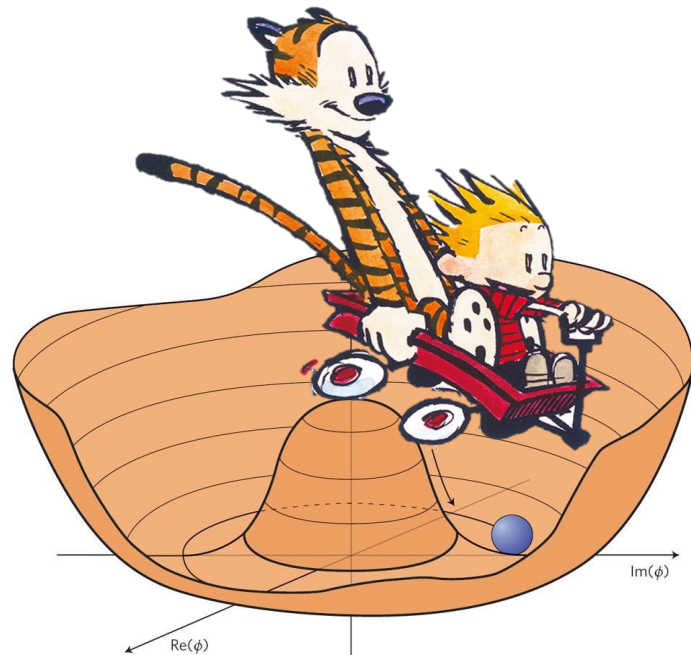

A fundamental question



How do
elementary
particles
get mass?

This is not a QFT lecture...

All microscopic phenomena seems to be well described by a remarkably simple *theory* (that we continue to call “model” only for historical reasons...)

$$\mathcal{L}_{\text{SM}} = \mathcal{L}_{\text{gauge}}(\psi_i, A_a) + \mathcal{L}_{\text{Higgs}}(H, A_a, \psi_i)$$

massless particles interact by exchanges of forces carried by *massless* gauge bosons. QFT describes *free fields*, interactions generated by *gauge symmetries* (thus *renormalizable*)

mass terms cannot be directly added without breaking theory gauge invariance (i.e. mass is not a fundamental property, rather an emerging phenomenon)

	mass → charge → spin →	≈2.3 MeV/c ² 2/3 1/2 u up	≈1.275 GeV/c ² 2/3 1/2 c charm	≈173.07 GeV/c ² 2/3 1/2 t top	0 0 1 g gluon	≈126 GeV/c ² 0 0 H Higgs boson
QUARKS		≈4.8 MeV/c ² -1/3 1/2 d down	≈95 MeV/c ² -1/3 1/2 s strange	≈4.18 GeV/c ² -1/3 1/2 b bottom	0 0 1 γ photon	
		0.511 MeV/c ² -1 1/2 e electron	105.7 MeV/c ² -1 1/2 μ muon	1.777 GeV/c ² -1 1/2 τ tau	0 0 1 Z Z boson	
LEPTONS		<2.2 eV/c ² 0 1/2 ν_e electron neutrino	<0.17 MeV/c ² 0 1/2 ν_μ muon neutrino	<15.5 MeV/c ² 0 1/2 ν_τ tau neutrino	±1 1 W W boson	GAUGE BOSONS

Theory would not make sense without a *Higgs field* (or something similar) responsible for *spontaneous symmetry breaking* and *mass generation*...

2.

An idea from 1964



What's hot in physics in 1964?

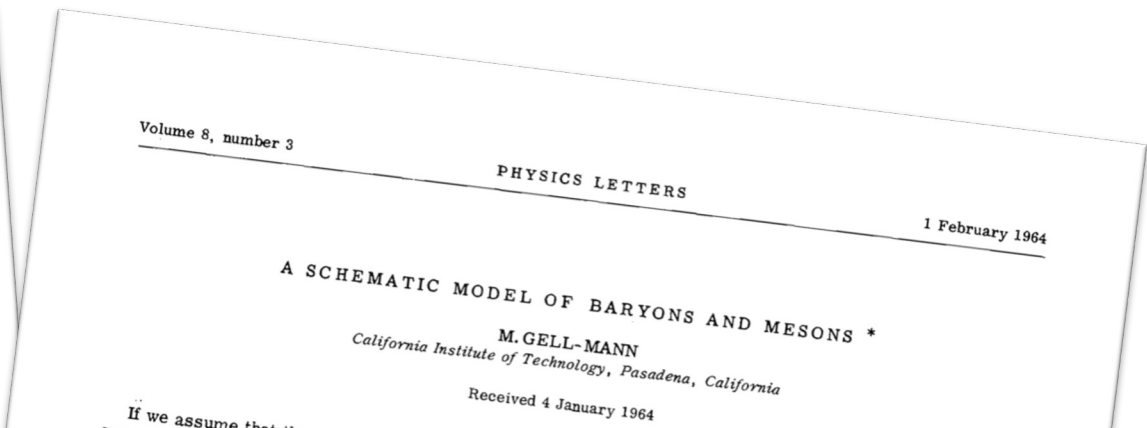
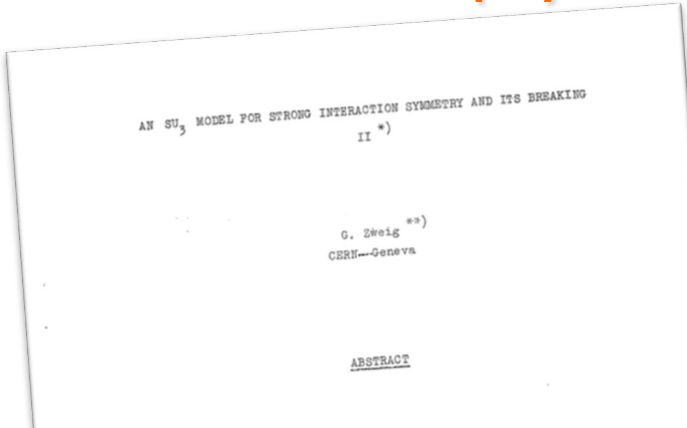

VOLUME 12, NUMBER 8

PHYSICAL REVIEW LETTERS

24 FEBRUARY 1964

OBSERVATION OF A HYPERON WITH STRANGENESS MINUS THREE*

If we assume that the

or all known baryons and
ing example of such a
riplet has spin $\frac{1}{2}$ and
icles d^- , s^- , u^0 and b^0
ptons.

nt scheme can be
integral values for the
tely with the basic
riplet t the following
d baryon number $\frac{1}{3}$.
 $u^{\frac{2}{3}}$, $d^{-\frac{1}{3}}$, and $s^{-\frac{1}{3}}$ of
d the members of the
Baryons can now be
ing the combinations
mesons are made out
ming that the lowest
s just the represen-
en observed, while
 $q\bar{q}$) similarly gives

Both mesons are
three fundamental part
into an isospin doublet
number $1/3$ and is fr
Eightfold Way) is ad
interactions. The bre
universal, being due
Extensive space-time
predicted for both me
ting experimental inf
presented concerning
definitively classifi
interaction theory b
to predict rates for
experimental search

*) Version I is
**) This work wa
of Sci
of Sci

8419/TH.412
21 February 1964

FIG. 2. Photograph and line diagram of event showing decay of Ω^- .

based on field
rks exactly as for
or example 3)
ed to a neut

EVIDENCE FOR THE 2π DECAY OF THE K_2^0 MESON*†

J. H. Christenson, J. W. Cronin,‡ V. L. Fitch,‡ and R. Turlay§

Princeton University, Princeton, New Jersey

(Received 10 July 1964)

This Letter reports the results of experimental studies designed to search for the 2π decay of the K_2^0 meson. Several previous experiments have served^{1,2} to set an upper limit on the branching fraction.

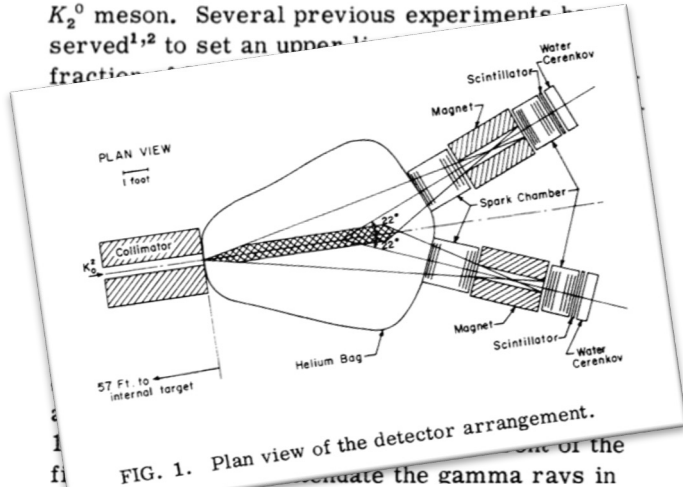

The analysis program computed the vector momenta of each charged particle observed in the decay, assuming

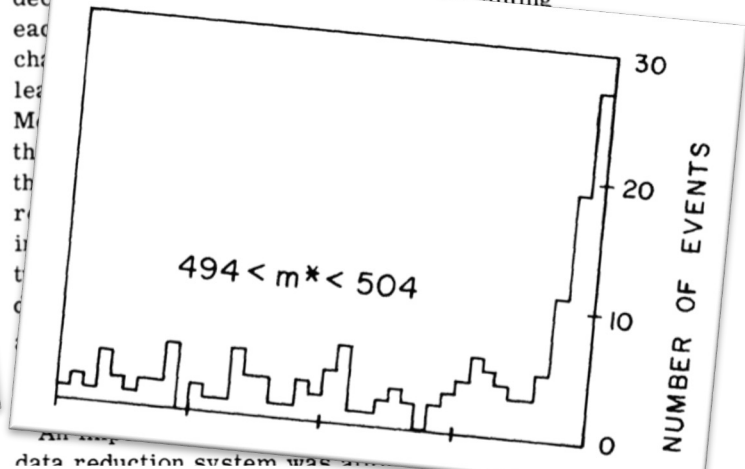

The Brout-Englert-Higgs mechanism is also proposed...

... and barely noticed!

BROKEN SYMMETRY AND THE MASS OF GAUGE VECTOR MESONS*
F. Englert and R. Brout
Faculté des Sciences, Université Libre de Bruxelles, Bruxelles, Belgium
(Received 26 June 1964)

14 citations in the first 5 years

BROKEN SYMMETRIES, MASSLESS PARTICLES AND GAUGE FIELDS
P. W. HIGGS
Tait Institute of Mathematical Physics, University of Edinburgh, Scotland
Received 27 July 1964

18 citations in the first 5 years

VOLUME 13, NUMBER 16 PHYSICAL REVIEW LETTERS 19 OCTOBER 1964

BROKEN SYMMETRIES AND THE MASSES OF GAUGE BOSONS
Peter W. Higgs
Tait Institute of Mathematical Physics, University of Edinburgh, Edinburgh, Scotland
(Received 31 August 1964)

11 citations in the first 5 years

GLOBAL CONSERVATION LAWS AND MASSLESS PARTICLES*
G. S. Guralnik,† C. R. Hagen,‡ and T. W. B. Kibble
Department of Physics, Imperial College, London, England
(Received 12 October 1964)

23 citations in the first 5 years

It would take 10 more years to become “mainstream”...

PHYSICAL REVIEW

VOLUME 155, NUMBER 5

25 MARCH 1967

1967

Symmetry Breaking in Non-Abelian Gauge Theories*

T. W. B. KIBBLE

Department of Physics, Imperial College, London, England

(Received 24 October 1966)

Photon remains massless

1967

Electroweak Symmetry Breaking
incorporated into
Standard Model

A MODEL OF LEPTONS*

Steven Weinberg†

Laboratory for Nuclear Science and Physics Department,
Massachusetts Institute of Technology, Cambridge, Massachusetts

(Received 17 October 1967)

A. Salam, “Weak And Electromagnetic Interactions,” Originally printed in “N. Svartholm: Elementary Particle Theory, Proceedings of The Nobel Symposium Held 1968 at Lerum, Sweden” 367-377 (1968).

RENORMALIZABLE LAGRANGIANS FOR MASSIVE YANG-MILLS FIELDS

G. 't HOOFT

Institute for Theoretical Physics, University of Utrecht

Received 13 July 1971

REGULARIZATION AND RENORMALIZATION OF GAUGE FIELDS

G. 't HOOFT and M. VELTMAN

*Institute for Theoretical Physics *, University of Utrecht*

Received 21 February 1972

1971-72

Standard Model is renormalizable

3.



A closer look to the SM Lagrangian



“This equation neatly sums up our current **understanding** of fundamental particles and forces”

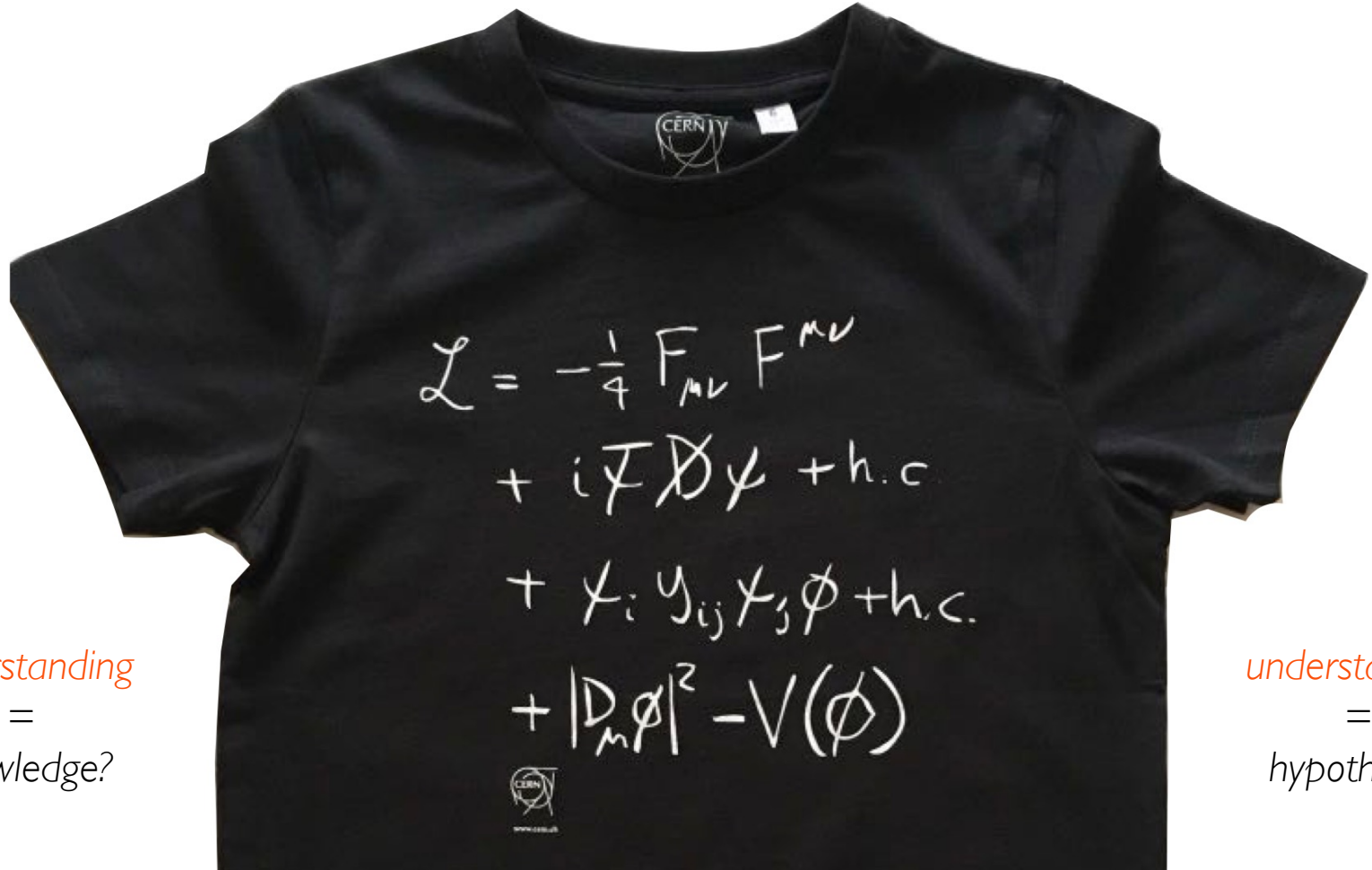

understanding
=
knowledge?

understanding
=
hypothesis?

Gauge sector

This part is very well known (one could even say since the discovery of Maxwell equations in 1880), elegant and very well experimentally verified!

$$\mathcal{L} = -\frac{1}{4} F_{\mu\nu} F^{\mu\nu} + i\bar{\psi}\not{D}\psi$$

$$+ \chi_i y_{ij} \chi_j \phi + h.c.$$

$$+ |D_\mu \phi|^2 - V(\phi)$$

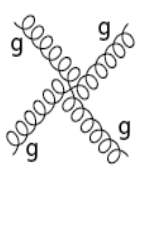
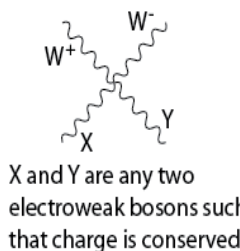
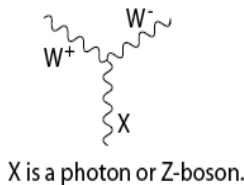
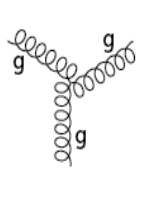
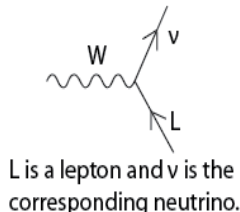
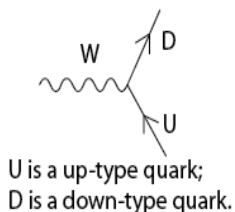
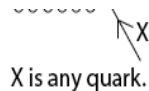

This equation neatly sums up our current understanding of fundamental particles and forces.

understanding = knowledge

Electro-weak symmetry breaking

Still a gauge interaction (nothing new, one might be tempted to say...), only this time **between bosons and a scalar field!**

Nothing like this directly observed before 2012 (but tested before by precision electroweak interactions)

Experimentally observed in 2012 with Higgs boson discovery...

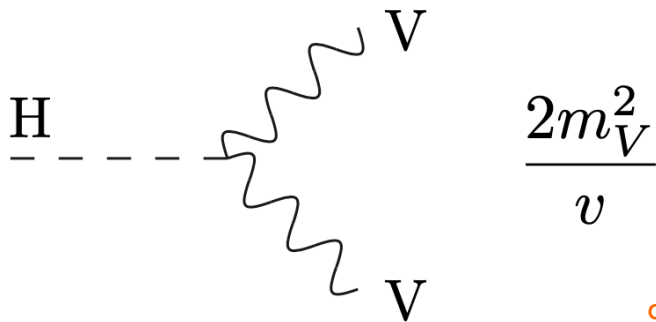

...this term could not exist without a v.e.v.

$$\begin{aligned} \mathcal{L} = & -\frac{1}{4} F_{\mu\nu} F^{\mu\nu} \\ & + i\bar{\psi} \not{D} \psi \\ & + \chi_i Y_{ij} \chi_j \phi + \text{h.c.} \\ & + |D_\mu \phi|^2 - V(\phi) \end{aligned}$$

This equation neatly sums up our current understanding of fundamental particles and forces.

Fermion masses via Yukawa interaction

Before 2012 this term was almost a conjecture... and even after the discovery in 2012, it remains an “anomalous” term (it’s *not a gauge interaction*, and no interaction with this structure has *ever been observed in nature*)

Is the Higgs boson responsible for the EW symmetry breaking also responsible for the masses of fermions?

Is the Higgs boson responsible for the masses of all fermions?

understanding = hypothesis

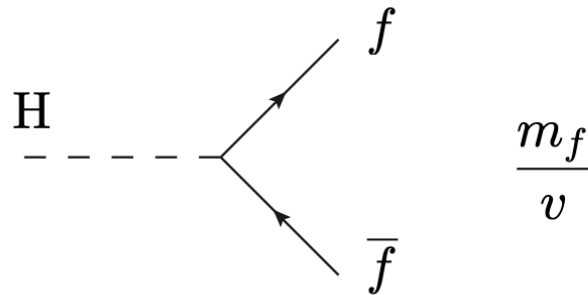

$$\begin{aligned} \mathcal{L} = & -\frac{1}{4} F_{\mu\nu} F^{\mu\nu} \\ & + i\bar{\psi} \not{D} \psi \\ & + \chi_i Y_{ij} \chi_j \phi + \text{h.c.} \\ & + |D_\mu \phi|^2 - V(\phi) \end{aligned}$$

This equation neatly sums up our current understanding of fundamental particles and forces.

$$\mathcal{L} = -\frac{1}{4} F_{\mu\nu} F^{\mu\nu} + i\bar{\psi}\not{D}\psi + \chi_i Y_{ij} \chi_j \phi + h.c. + |D_\mu \phi|^2 - V(\phi)$$

Higgs potential

$$V(\Phi) = -\mu^2 \Phi^\dagger \Phi + \lambda (\Phi^\dagger \Phi)^2$$

It defines all characteristics of Higgs field and defines Higgs self-interaction properties. Nothing like this has **ever been observed in nature**

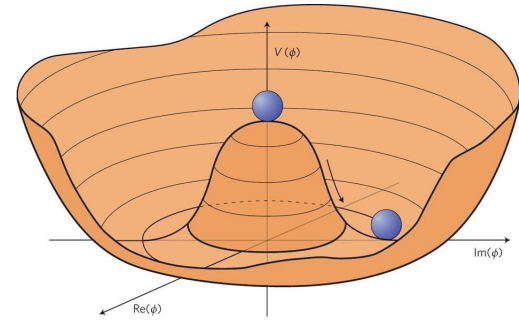

Is the shape of the Higgs potential that postulated by the Standard Model?

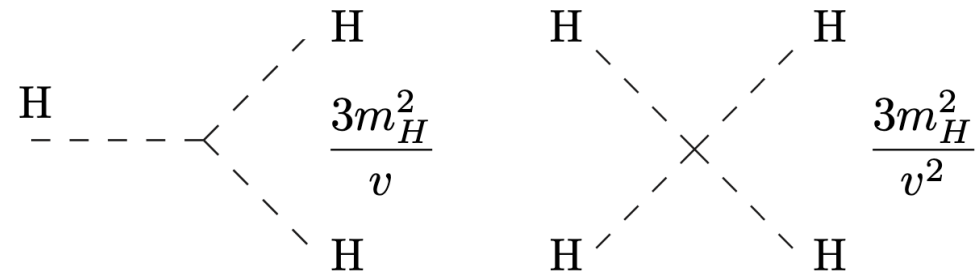

This equation neatly sums up our current understanding of fundamental particles and forces.

A couple of things about the Higgs potential...

$$V(\Phi) = -\mu^2 \Phi^\dagger \Phi + \lambda (\Phi^\dagger \Phi)^2$$

The potential is *symmetric under rotations in Φ space*

It has a minimum which is *not at $\langle \Phi \rangle = 0$* known as the *vacuum expectation value (vev) v* that defines the *electroweak scale*

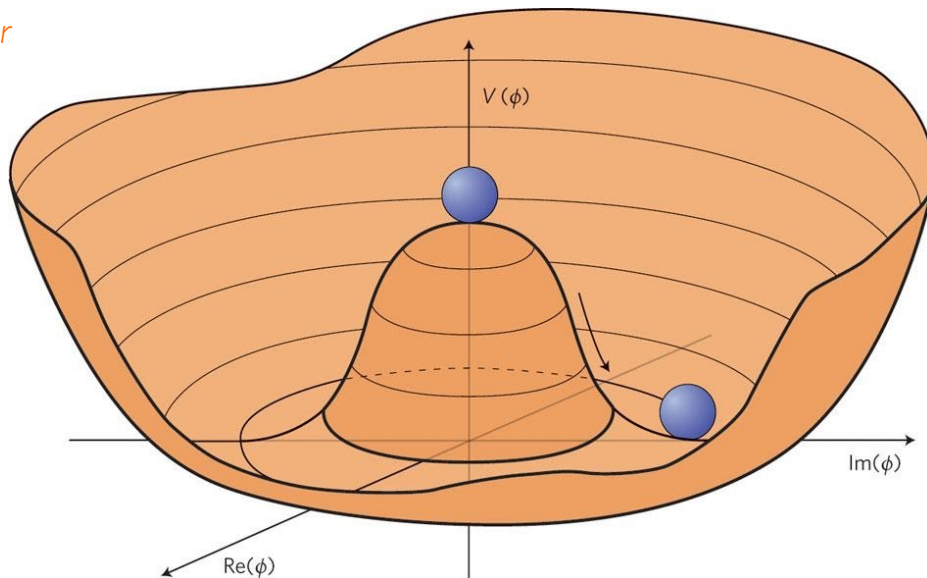

$$\mu^2 < 0$$

$$\lambda > 0$$

The mass of the Higgs boson is not predicted by the theory!

$$v = \frac{\mu}{\sqrt{\lambda}} = \frac{m_W}{g} = 246 \text{ GeV}$$

$$m_H = \sqrt{2}\mu = \sqrt{2\lambda}v$$

4.

Higgs before the LHC

1976

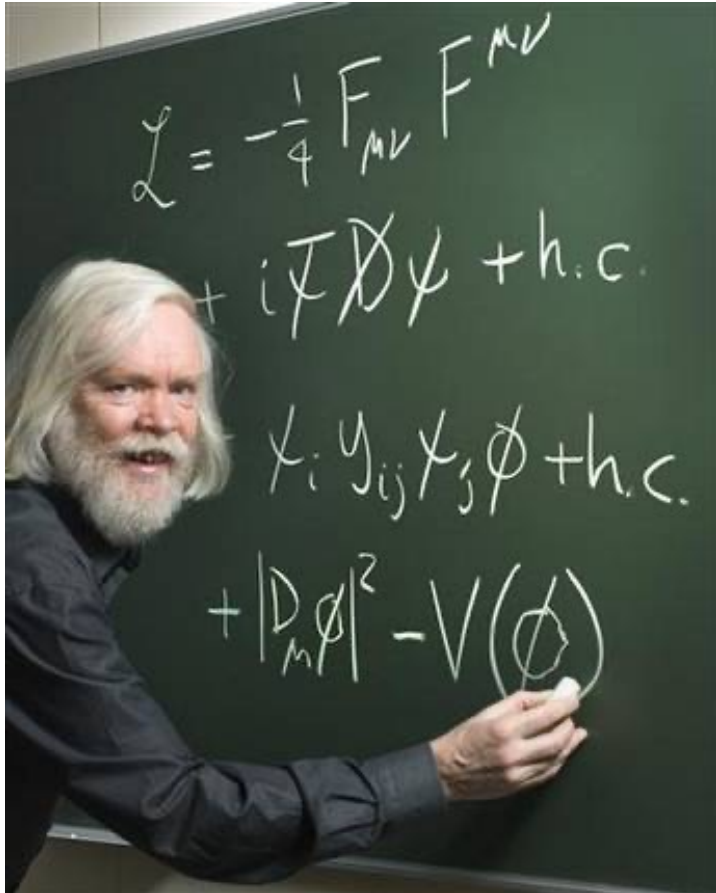

A PHENOMENOLOGICAL PROFILE OF THE HIGGS BOSON

John Ellis, Mary K. Gaillard ^{*)} and D.V. Nanopoulos ^{+))}
CERN -- Geneva

We should perhaps finish with an apology and a caution. We apologize to experimentalists for having no idea what is the mass of the Higgs boson, unlike the case with charm ^{3),4)} and for not being sure of its couplings to other particles, except that they are probably all very small. For these reasons we do not want to encourage big experimental searches for the Higgs boson, but we do feel that people performing experiments vulnerable to the Higgs boson should know how it may turn up.

Absolute lower limit on Higgs mass at LEP

- LEP1 e^+e^- at COM $\sim m_Z$
 - ✓ Various decays and topologies
 - ✓ Limit down to below $2 m_e$ using acoplanar lepton pairs (Higgs would be long lived)

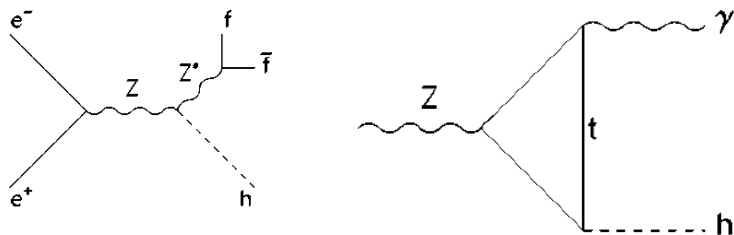

- LEP2 e^+e^- up to 209 GeV
 - ✓ mostly $b\bar{b}$ and $\tau\tau$ decays

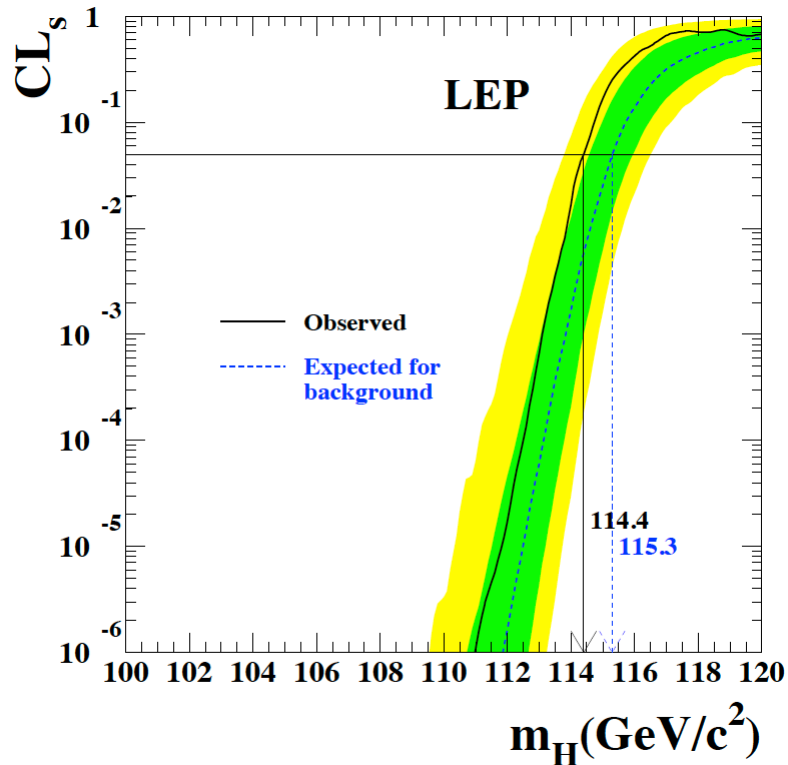
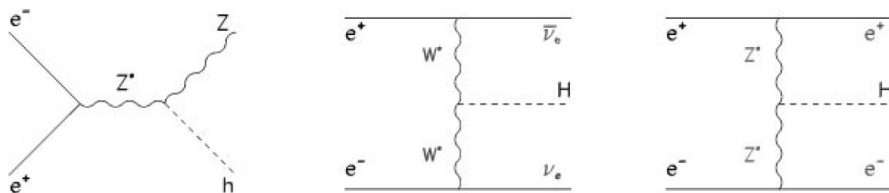

SM Higgs with mass below
114 GeV excluded

Electroweak precision data and the Higgs mass

Fermi Constant $G_F = 1.166367(5) \times 10^{-5} \text{ GeV}^{-2}$ (muon lifetime)
 Fine structure Constant $\alpha = 1/137.035999679(94)$ (quantum Hall effect)
 Z mass $M_Z = 91.1876 \pm 0.0021 \text{ GeV}$ (LEP)

$$G_F = \frac{\pi\alpha_{QED}}{\sqrt{2}m_W^2(1 - m_W^2/m_Z^2)}(1 + \Delta r)$$

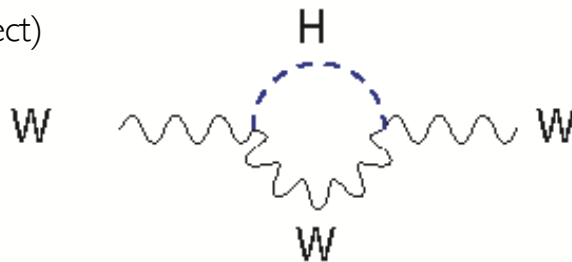

Measurement	Fit	$10^{meas} - 10^{fit}$	$10^{meas} - 10^{fit}$
$\Delta\alpha_{had}^{(5)}(m_Z)$	0.02750 ± 0.00033	0.02759	
m_Z [GeV]	91.1875 ± 0.0021	91.1874	
Γ_Z [GeV]	2.4952 ± 0.0023	2.4959	
σ_{had}^0 [nb]	41.540 ± 0.037	41.478	
R_b	20.767 ± 0.025	20.742	
$A_{FB}^{0,b}$	0.01714 ± 0.00095	0.01645	
$A_{FB}^{0,c}$	0.1465 ± 0.0032	0.1481	
R_b	0.21629 ± 0.00066	0.21579	
R_c	0.1721 ± 0.0030	0.1723	
$A_{FB}^{b,c}$	0.0992 ± 0.0016	0.1038	
$A_{FB}^{c,b}$	0.0707 ± 0.0035	0.0742	
A_b	0.923 ± 0.020	0.935	
A_c	0.670 ± 0.027	0.668	
$A_{\tau}(SLD)$	0.1513 ± 0.0021	0.1481	
$\sin^2\theta_{eff}^{lept}(Q_b)$	0.2324 ± 0.0012	0.2314	
m_W [GeV]	80.385 ± 0.015	80.377	
Γ_W [GeV]	2.085 ± 0.042	2.092	
m_t [GeV]	173.20 ± 0.90	173.26	

$$\Delta r \propto \log\left(\frac{m_H}{m_W}\right)$$

$$m_H = 94_{-24}^{+29} \text{ GeV}$$

$m_H < 152 \text{ GeV}$ at 95% CL

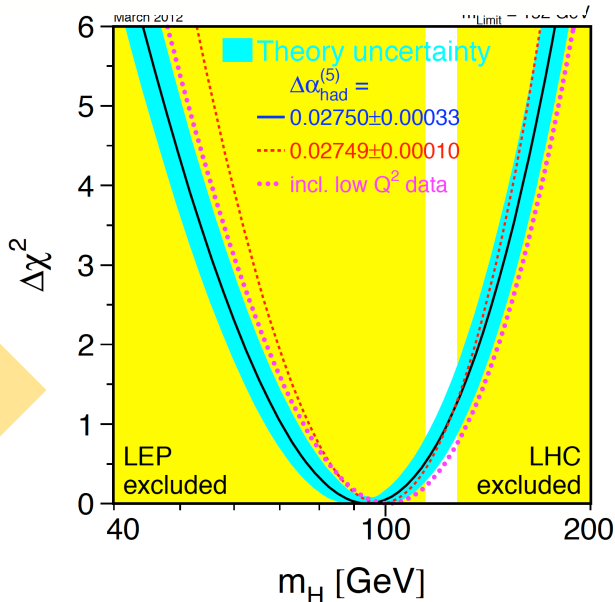

5.

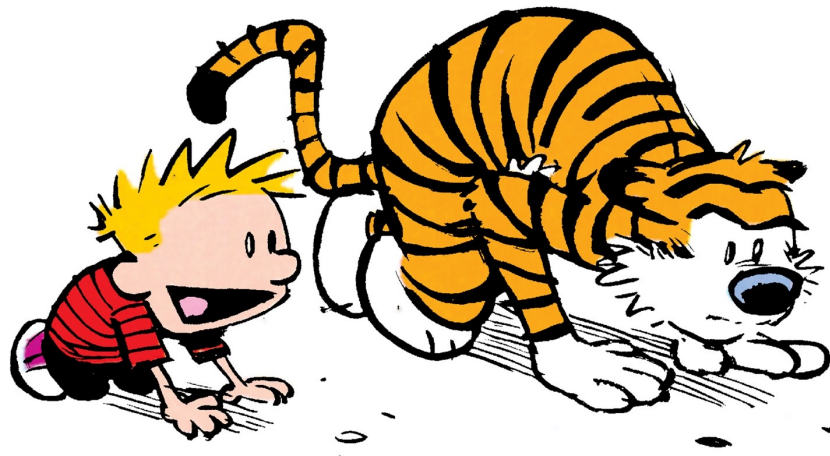

Enters the LHC

The LHC era begins...

- **1991 December CERN Council**
 - ✓ “LHC is the right machine for advance of the subject and the future of CERN” (thanks to the great push by DG C Rubbia)
- **1993 December proposal of LHC** with commissioning in 2002
- **1994 June Council**
 - ✓ Staged construction was proposed by DG Chris Llewellyn Smith, but some countries could not yet agree, so the Council session vote was suspended until
- **16 December 1994 Council**
 - ✓ (Two-stage) construction of LHC approved!

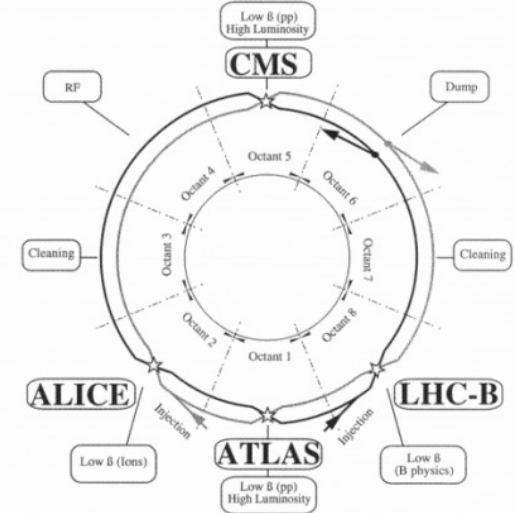
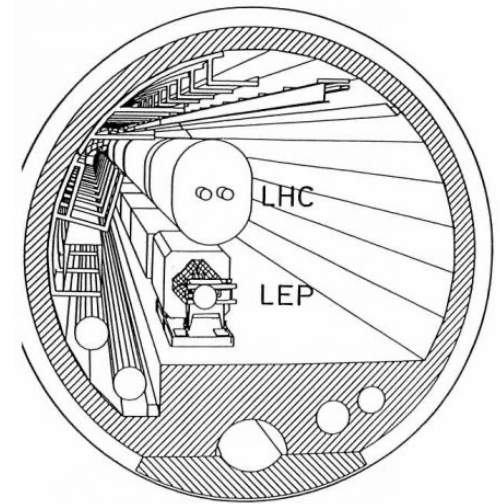

1990

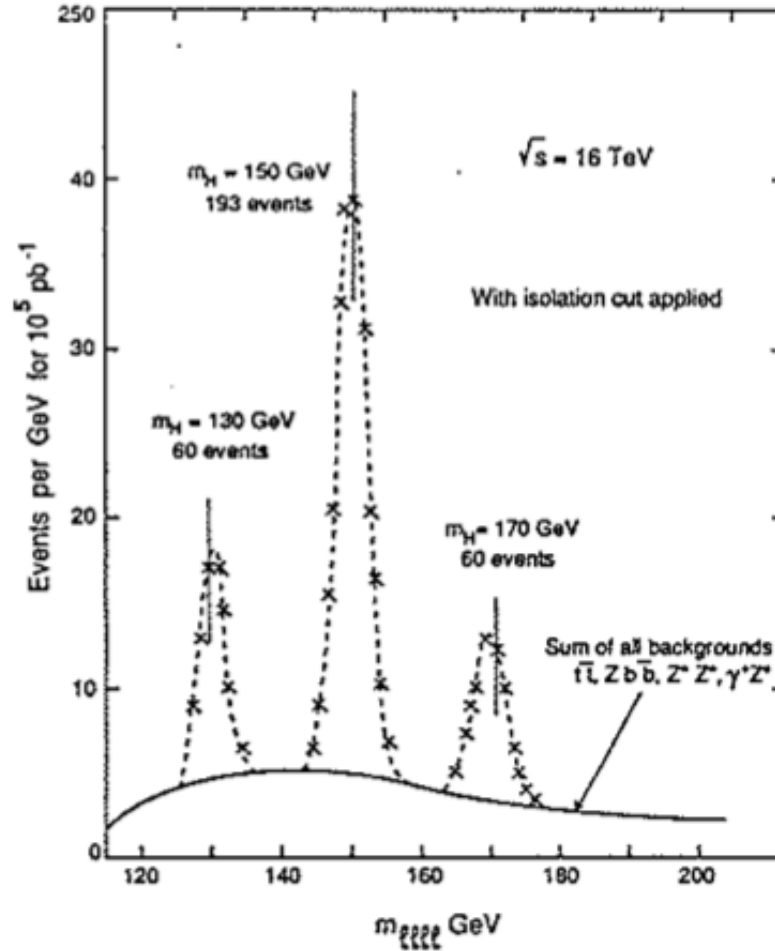

Proceedings of LHC Workshop
(Aachen, 1990)

$\sqrt{s} = 16 \text{ TeV}, 100 \text{ fb}^{-1}$

The Large Hadron Collider as we know it

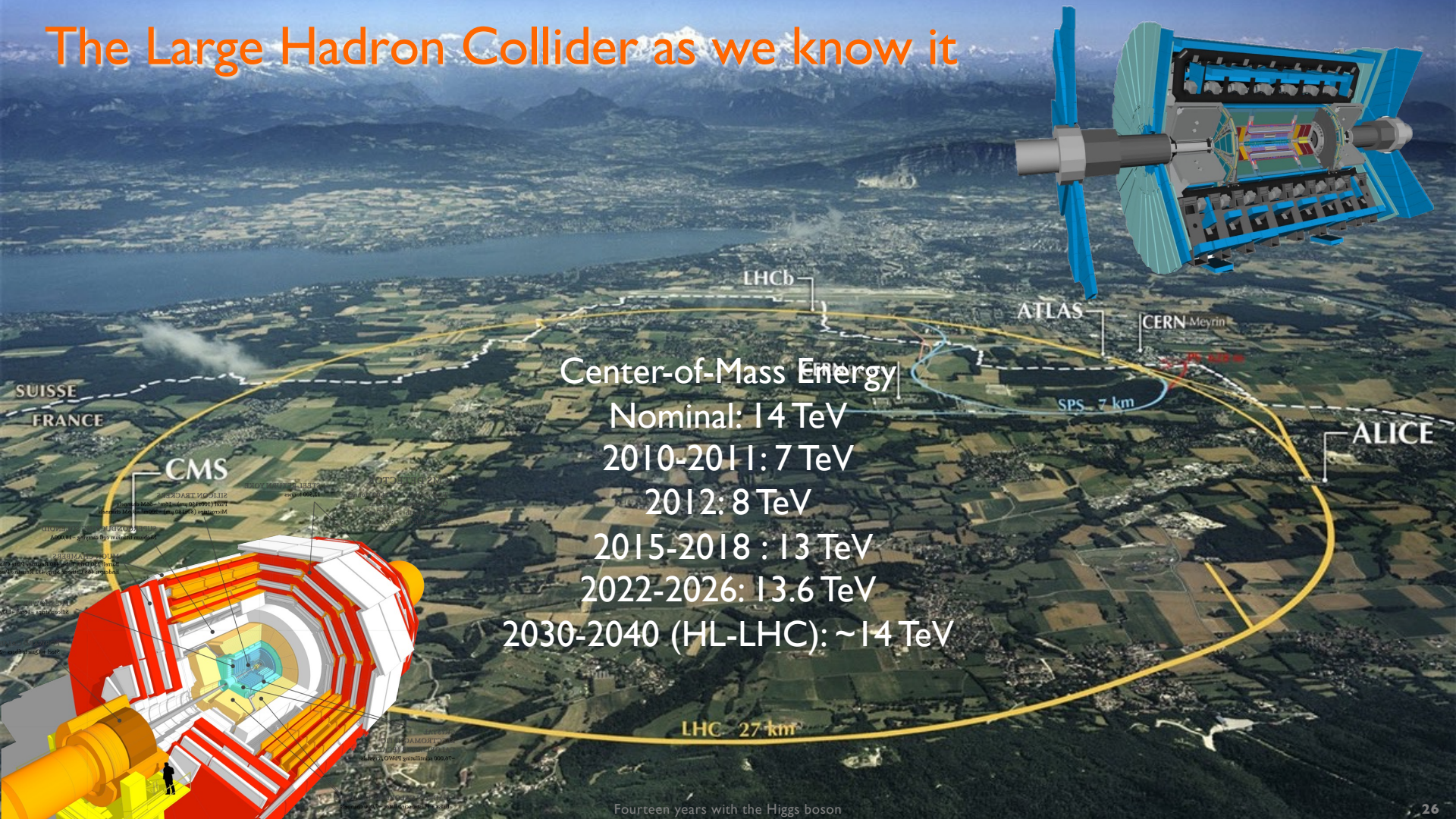

Center-of-Mass Energy
Nominal: 14 TeV
2010-2011: 7 TeV
2012: 8 TeV
2015-2018 : 13 TeV
2022-2026: 13.6 TeV
2030-2040 (HL-LHC): ~14 TeV

SUISSE
FRANCE

CMS

LHCb

ATLAS

CERN Meyrin

SPS - 7 km

ALICE

LHC - 27 km

6.



A textbook discovery

Higgs boson production at the LHC

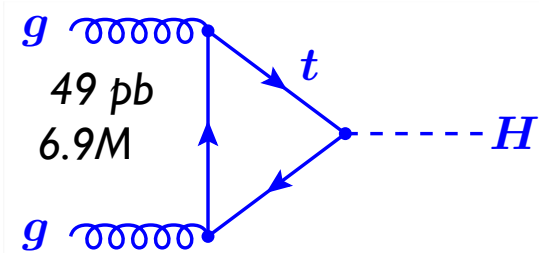

gluon-gluon fusion:
main production mode at
LHC

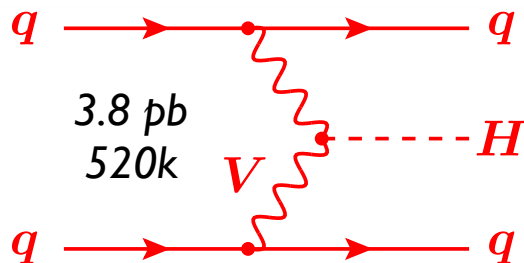

Vector Boson Fusion
2 well-separated forward
jets

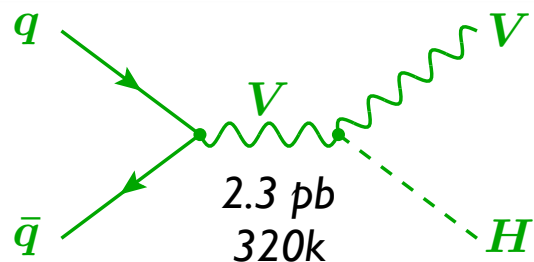

VH
tag W and Z
boson decays

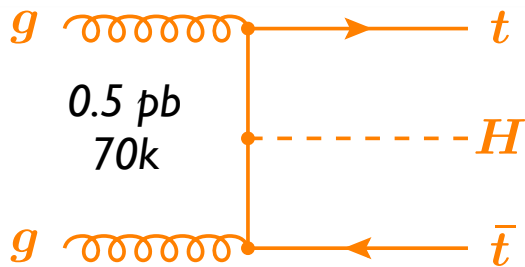

ttH
tag 2 top quarks

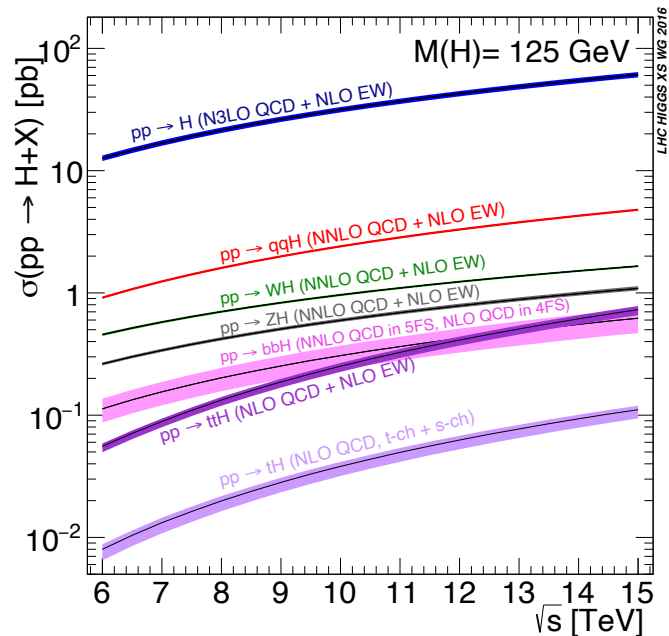

$\sigma[\text{pb}] @ 13 \text{ TeV}$

Higgs produced in 140 fb^{-1} in one experiment

The Higgs boson is an unstable particle

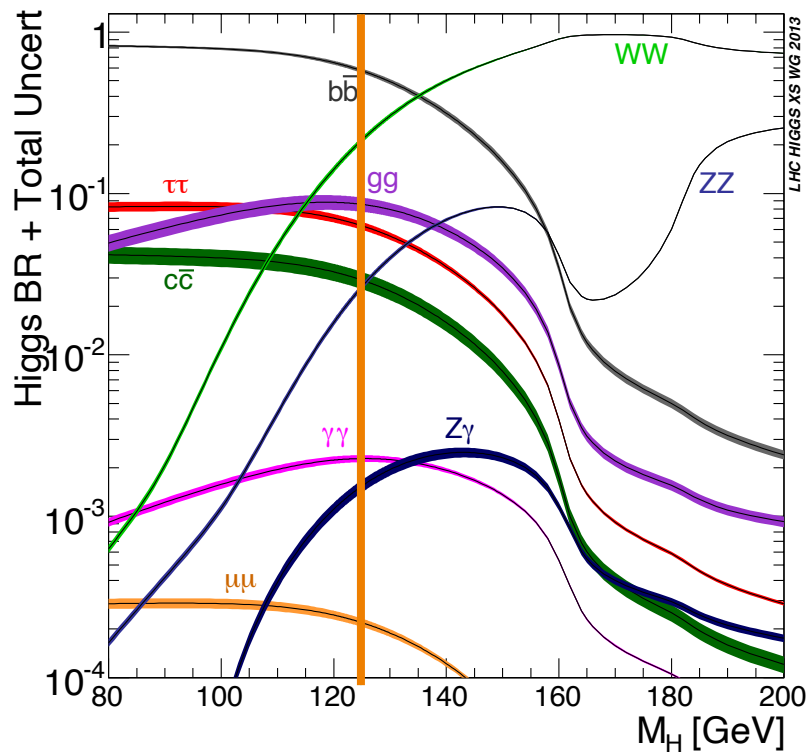

Higgs BR

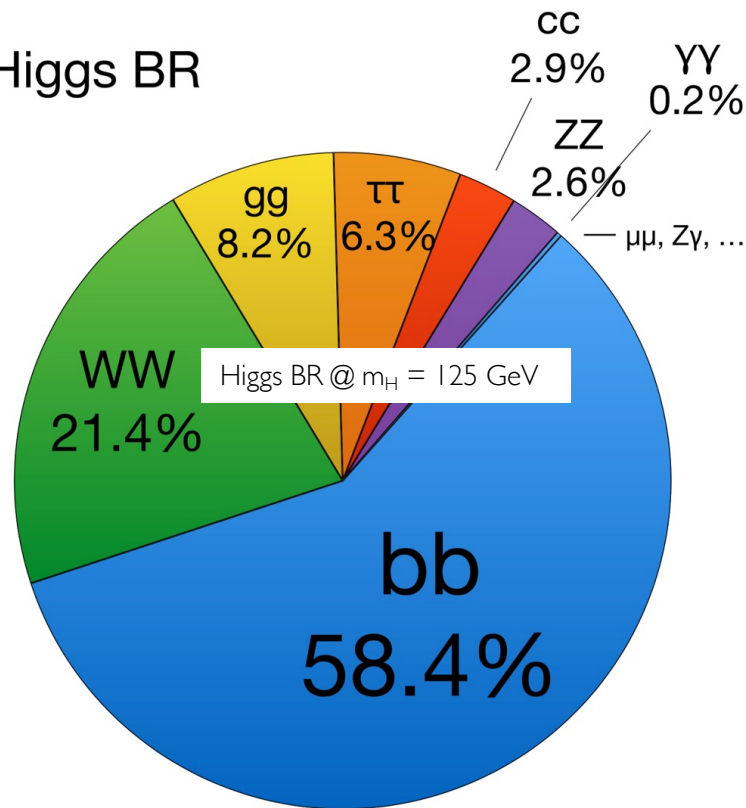

Almost exactly 14 years ago...

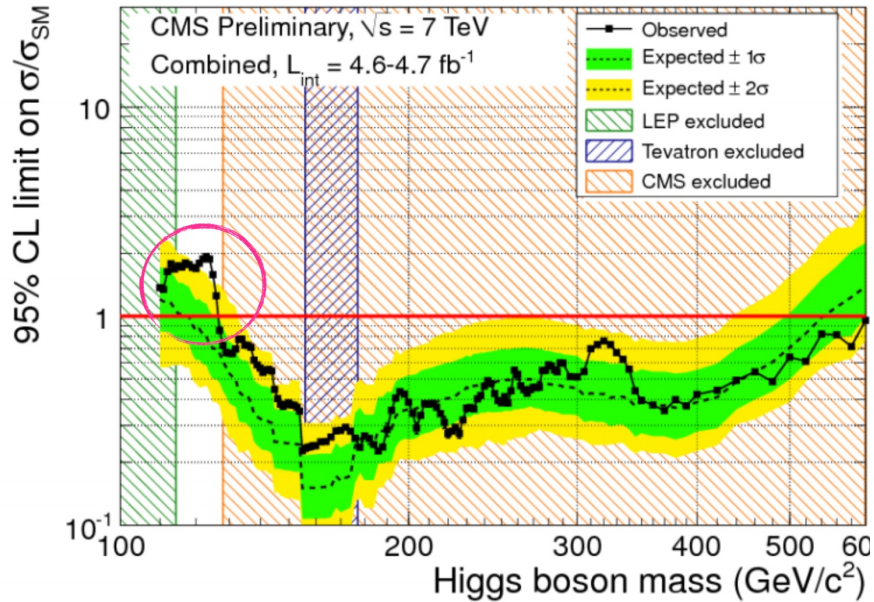

End of 2011...

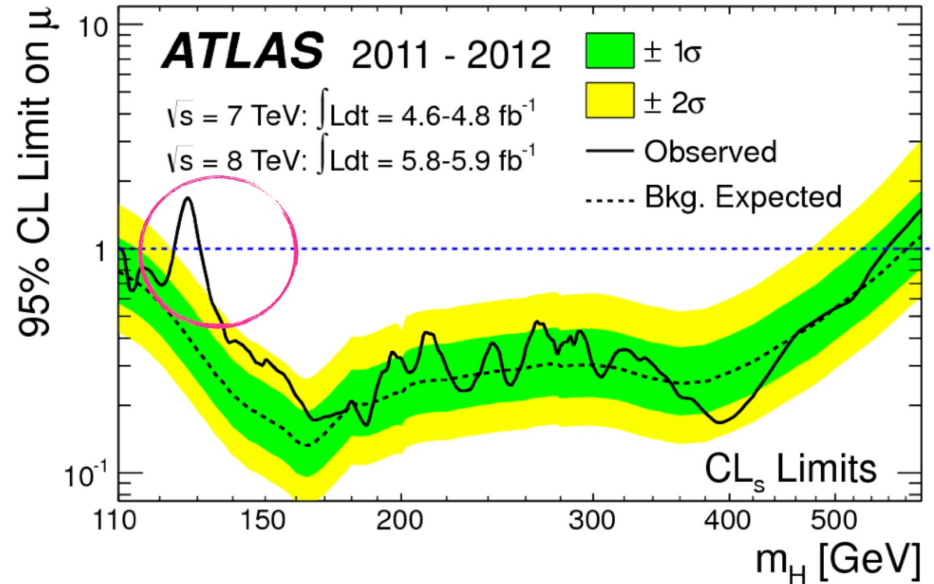

... June 2012...

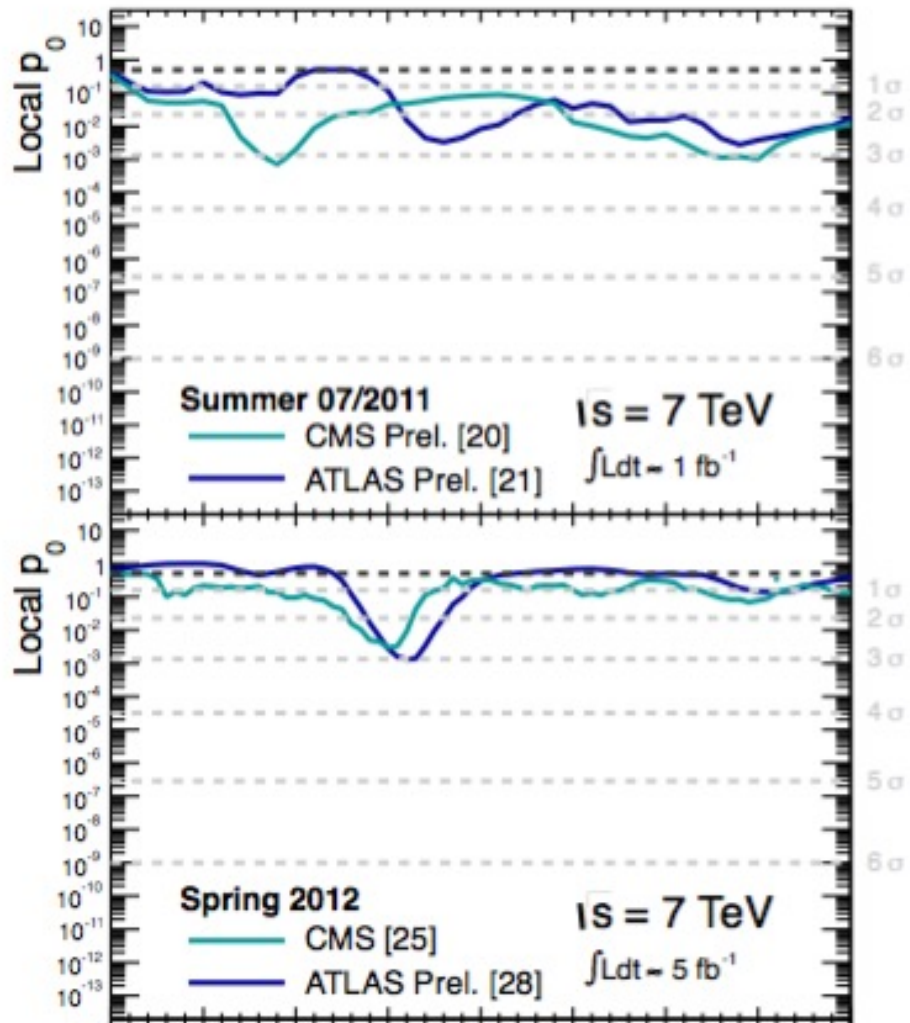

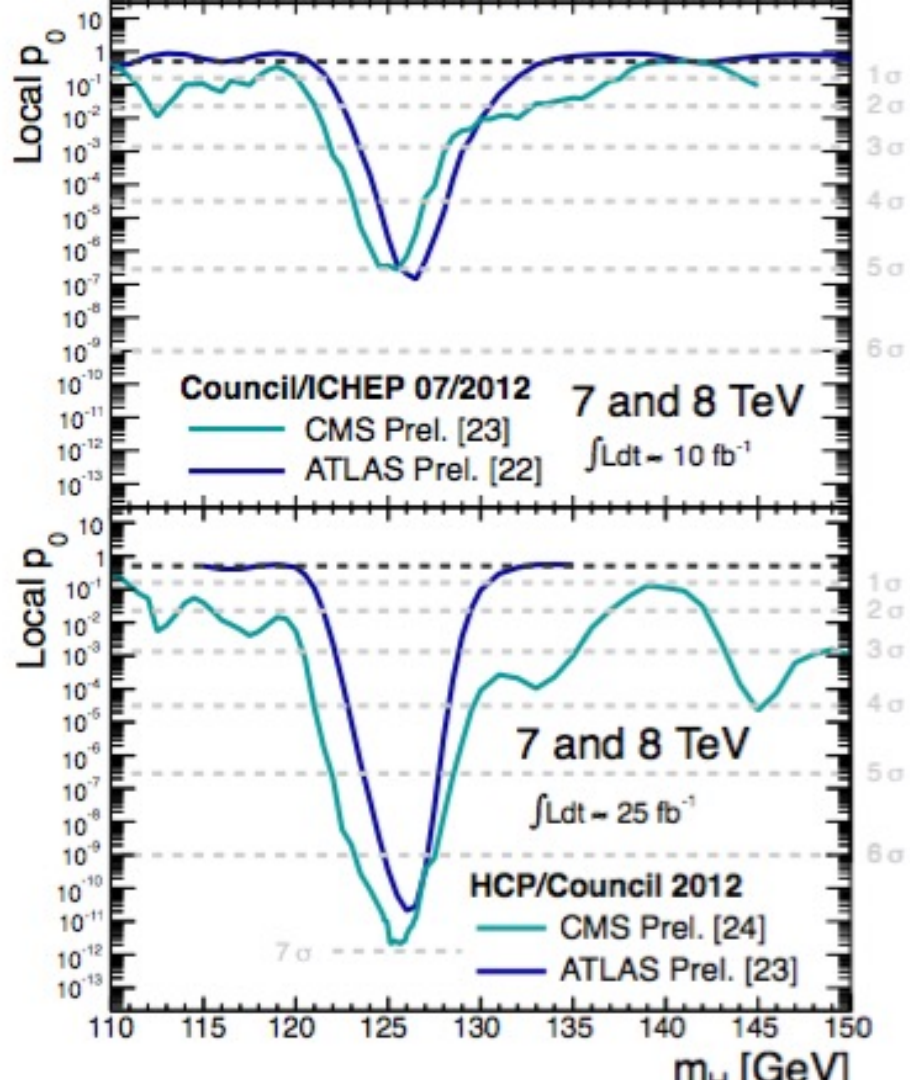

5σ !

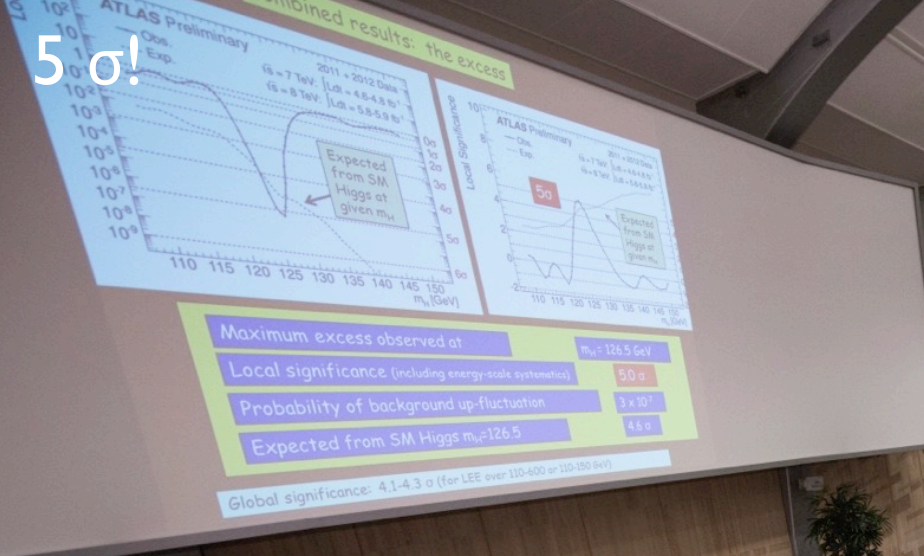

Fabiola Gianotti revealing the combined significance of the ATLAS Higgs searches on July 4 2012



Higgs boson discovery channels

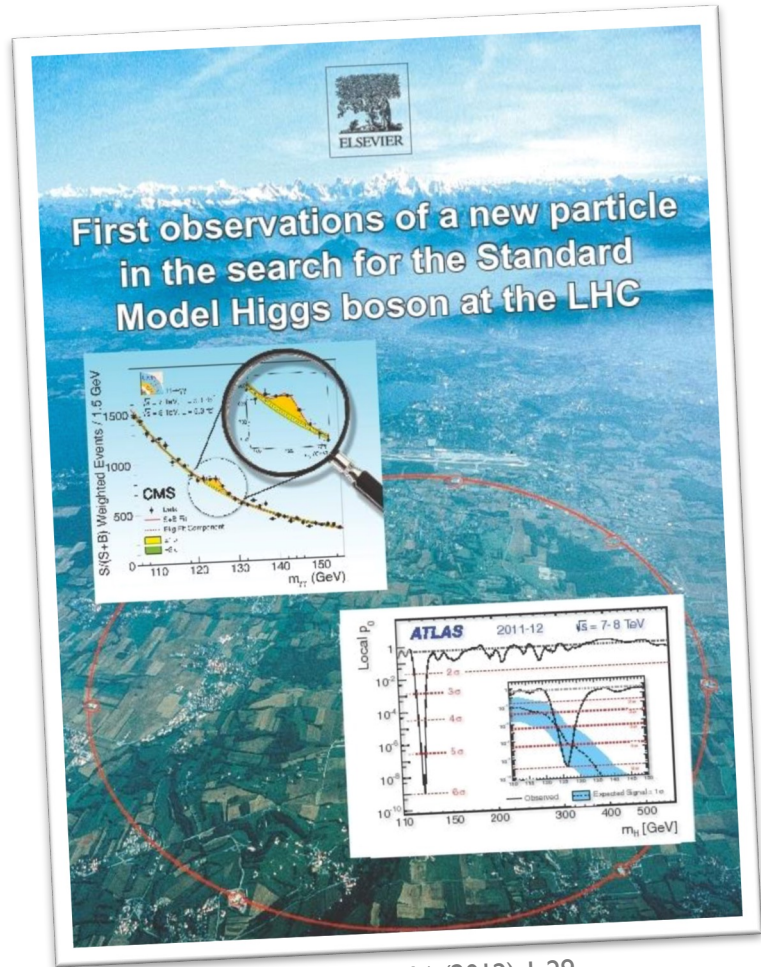

ATLAS: PLB 716 (2012) 1-29
CMS: PLB 716 (2012) 30

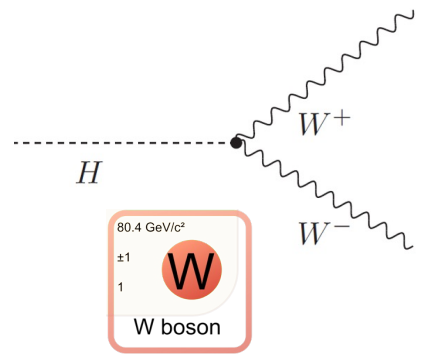
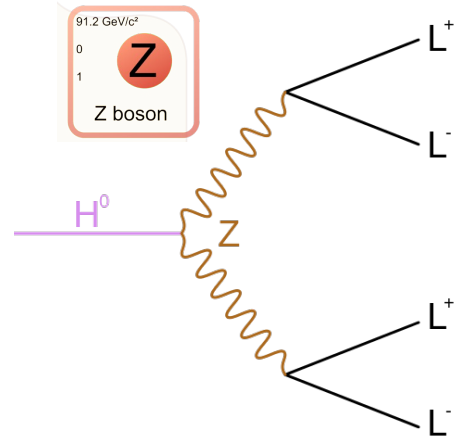
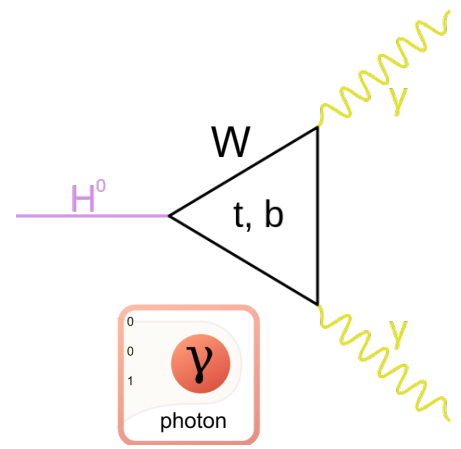

7.

14 years of Higgs measurements



A long way since the discovery...

2012

Phys Lett B 716 (1) 1-29 2012

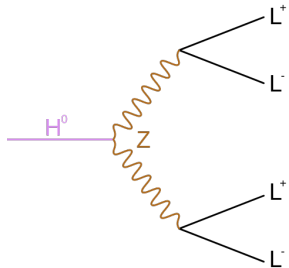
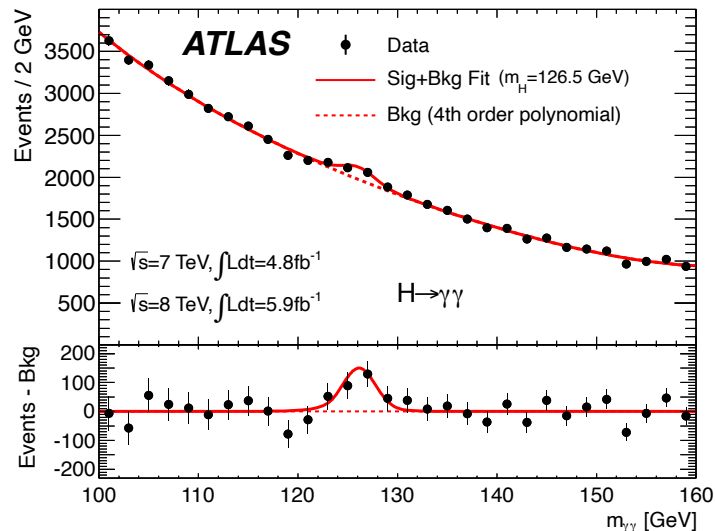
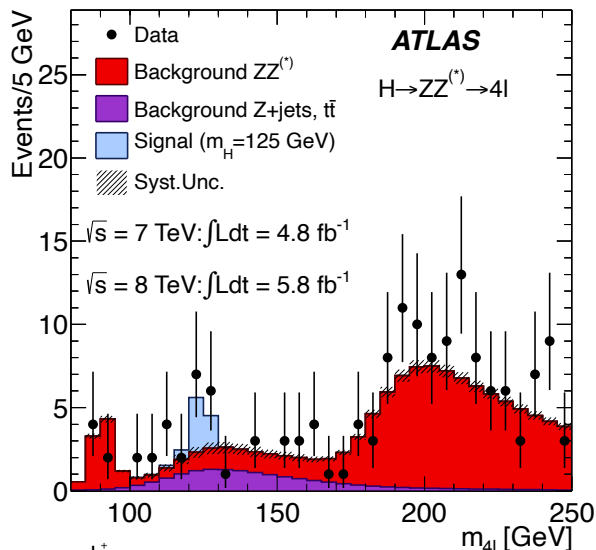

H^0 DECAY MODES	Fraction (Γ_i/Γ)	p (MeV/c)
$W W^*$	seen	—
$Z Z^*$	seen	—
$\gamma\gamma$	seen	—
$b\bar{b}$	possibly seen	—
$\tau^+ \tau^-$	possibly seen	—

Mass Limits for the Standard Model Higgs
 Mass $m > 122$ and none 127–600 GeV, CL = 95%

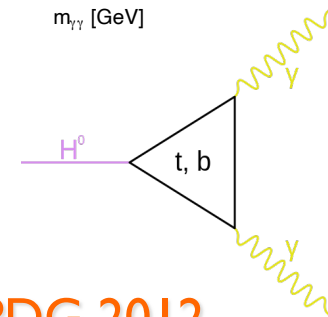

PDG 2012

J. Beringer *et al.* (Particle Data Group), PR **D86**, 010001 (2012)

A long way since the discovery...

YESTERDAY

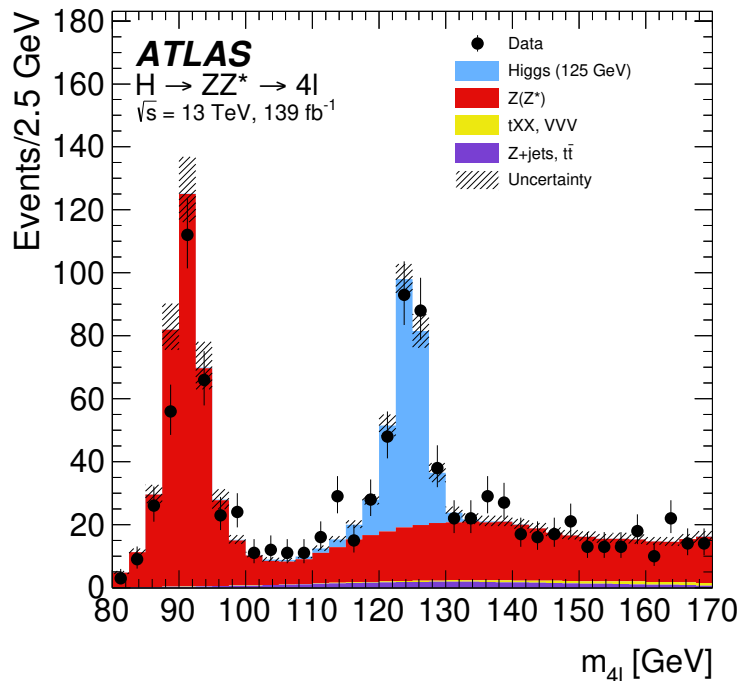

[Eur. Phys. J. C 80 \(2020\) 942](#)

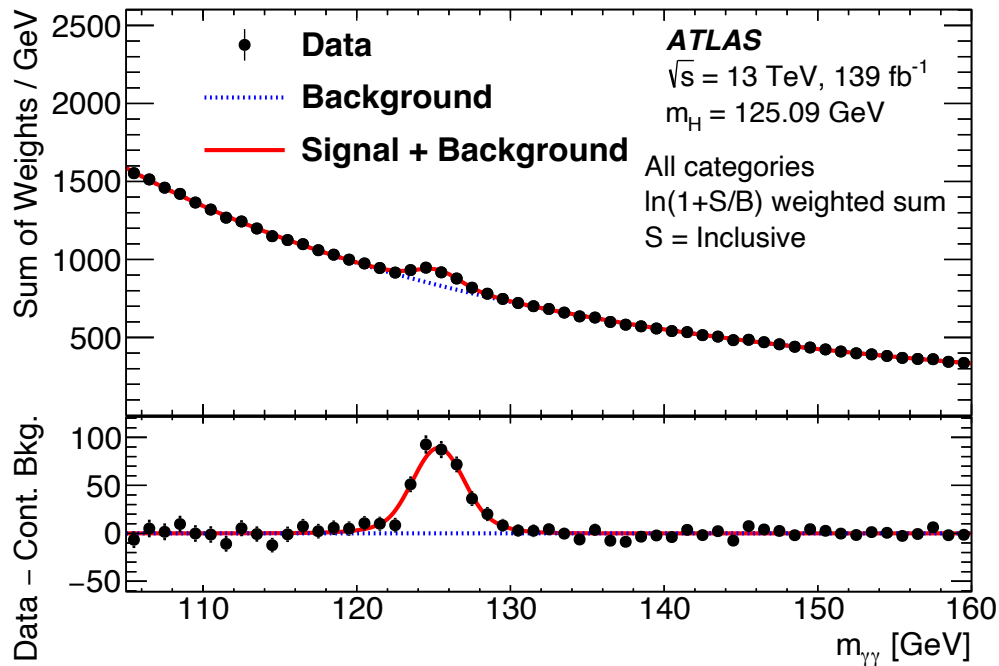

[JHEP 07 \(2023\) 088](#)

A long way since the discovery...

PDG 2022

H^0

$J = 0$

Mass $m = 125.25 \pm 0.17$ GeV ($S = 1.5$)
 Full width $\Gamma = 3.2_{-2.2}^{+2.8}$ MeV (assumes equal
 on-shell and off-shell effective couplings)

H^0 Signal Strengths in Different Channels

Combined Final States = 1.13 ± 0.06

$W W^* = 1.19 \pm 0.12$

$Z Z^* = 1.01 \pm 0.07$

$\gamma\gamma = 1.10 \pm 0.07$

$c\bar{c}$ Final State = 37 ± 20

$b\bar{b} = 0.98 \pm 0.12$

$\mu^+\mu^- = 1.19 \pm 0.34$

$\tau^+\tau^- = 1.15_{-0.15}^{+0.16}$

$Z\gamma < 3.6$, CL = 95%

$\gamma^*\gamma$ Final State = 1.5 ± 0.5

$t\bar{t}H^0$ Production = 1.10 ± 0.18

tH^0 production = 6 ± 4

H^0 Production Cross Section in pp Collisions at $\sqrt{s} = 13$ TeV =
 56 ± 4 pb

H^0 DECAY MODES

H^0 DECAY MODES	Fraction (Γ_i/Γ)	Confidence level	p (MeV/c)
e^+e^-	$< 3.6 \times 10^{-4}$	95%	62625
$Z\rho(770)$	< 1.21 %	95%	29423
$Z\phi(1020)$	$< 3.6 \times 10^{-3}$	95%	29417
$J/\psi\gamma$	$< 3.5 \times 10^{-4}$	95%	62587
$J/\psi J/\psi$	$< 1.8 \times 10^{-3}$	95%	62548
$\psi(2S)\gamma$	$< 2.0 \times 10^{-3}$	95%	62571
$\Upsilon(1S)\gamma$	$< 4.9 \times 10^{-4}$	95%	62268
$\Upsilon(2S)\gamma$	$< 5.9 \times 10^{-4}$	95%	62224
$\Upsilon(3S)\gamma$	$< 5.7 \times 10^{-4}$	95%	62197
$\Upsilon(nS)\Upsilon(mS)$	$< 1.4 \times 10^{-3}$	95%	—
$\rho(770)\gamma$	$< 8.8 \times 10^{-4}$	95%	62623
$\phi(1020)\gamma$	$< 4.8 \times 10^{-4}$	95%	62621
$e\mu$	LF $< 6.1 \times 10^{-5}$	95%	62625
$e\tau$	LF $< 2.2 \times 10^{-3}$	95%	62612
$\mu\tau$	LF $< 1.5 \times 10^{-3}$	95%	62612
invisible	< 19 %	95%	—

R.L. Workman *et al* (PDG), Prog. Theor. Exp. Phys. **2022**, 083C01 (2022)

14 years with the Higgs boson, and the next 14+ years...

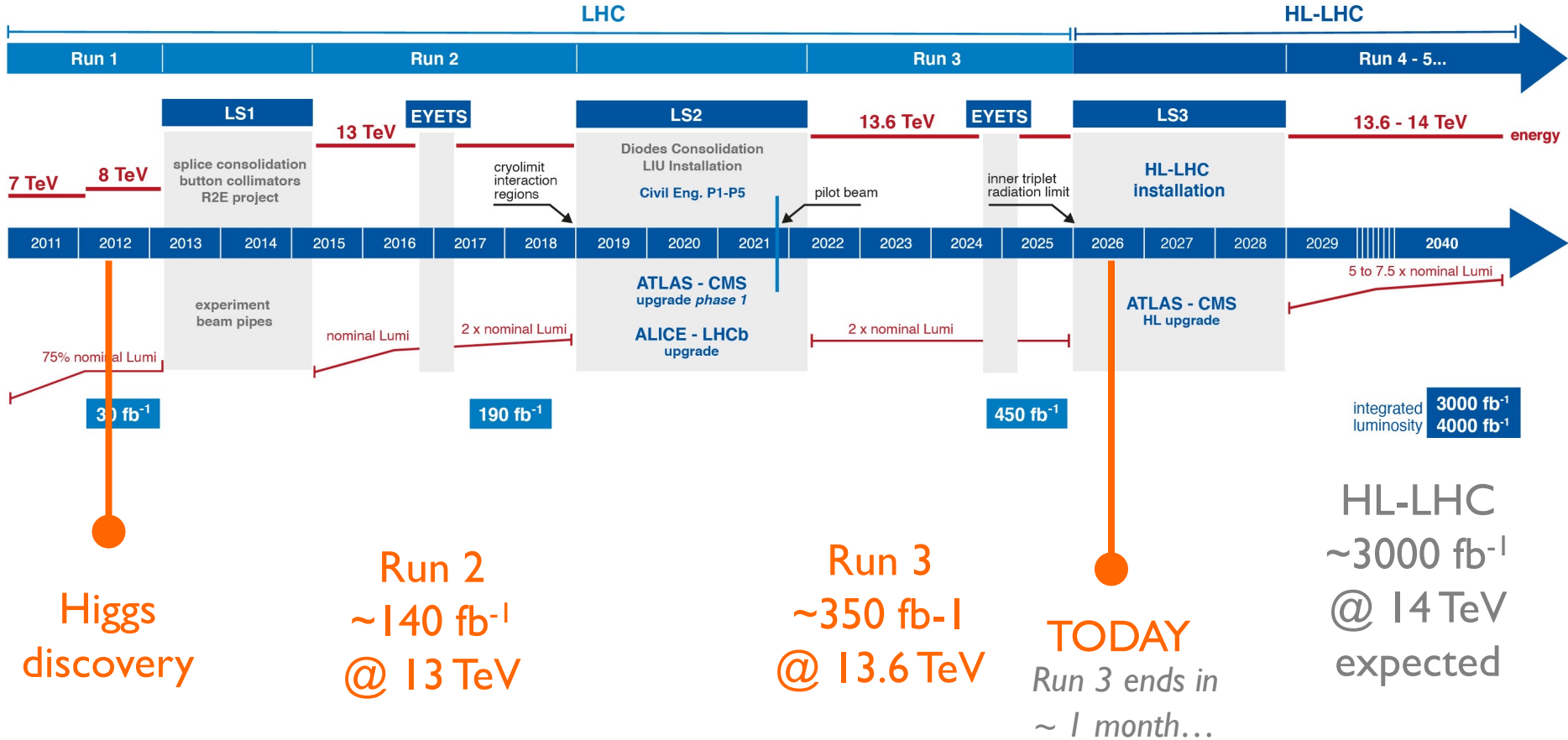

Higgs discovery

Run 2
~140 fb⁻¹
@ 13 TeV

Run 3
~350 fb⁻¹
@ 13.6 TeV

TODAY
Run 3 ends in
~ 1 month...

HL-LHC
~3000 fb⁻¹
@ 14 TeV
expected

8.

How well
do we know
the “basic”

Higgs properties?



Higgs boson mass and width

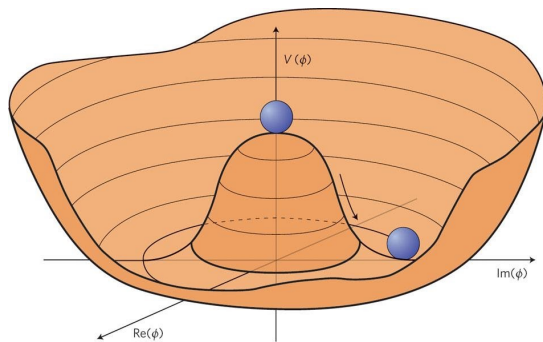

$$V(\Phi) = -\mu^2 \Phi^\dagger \Phi + \lambda (\Phi^\dagger \Phi)^2$$

$$\nu = \frac{\mu}{\sqrt{\lambda}}$$

$$V(\Phi) = V_0 + \frac{1}{2} m_H^2 H^2 + \lambda \nu H^3 + \frac{1}{4} \lambda H^4$$

$$m_H = \sqrt{2} \mu = \sqrt{2 \lambda} \nu$$

How well do we know the Higgs mass?

$$m_H = \sqrt{2}\mu$$

- m_H Not predicted by theory
- All Higgs coupling properties depend on m_H
- Excellent measurements by ATLAS and CMS
 - ✓ Precision depends on energy (photons, electrons) and momentum (muons) calibration

Phys. Rev. Lett. 131 (2023) 251802

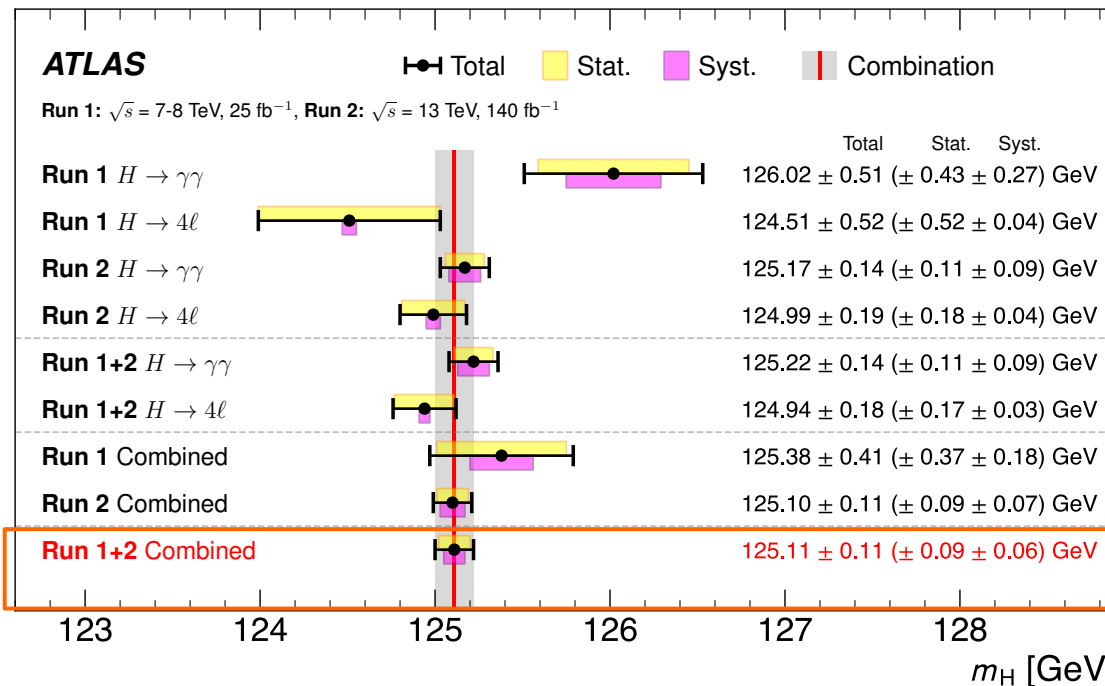

110 MeV
(0.09%)

Higgs width: a problem difficult to tackle directly!

Total Higgs natural width in SM is **small!**

- ✓ Too small to be accessed experimentally at LHC from resonance line-shape in analysis where peak can be reconstructed...

$$\Gamma_H^{\text{SM}} \text{ dominated by } \Gamma(H \rightarrow b\bar{b}) \approx \frac{N_c g_w^2 m_b^2 m_H}{32\pi m_W^2}$$

$$\Gamma_H^{\text{SM}} = 4.07 \text{ MeV}$$

Direct measurement severely limited by detector resolution! One (old) example:

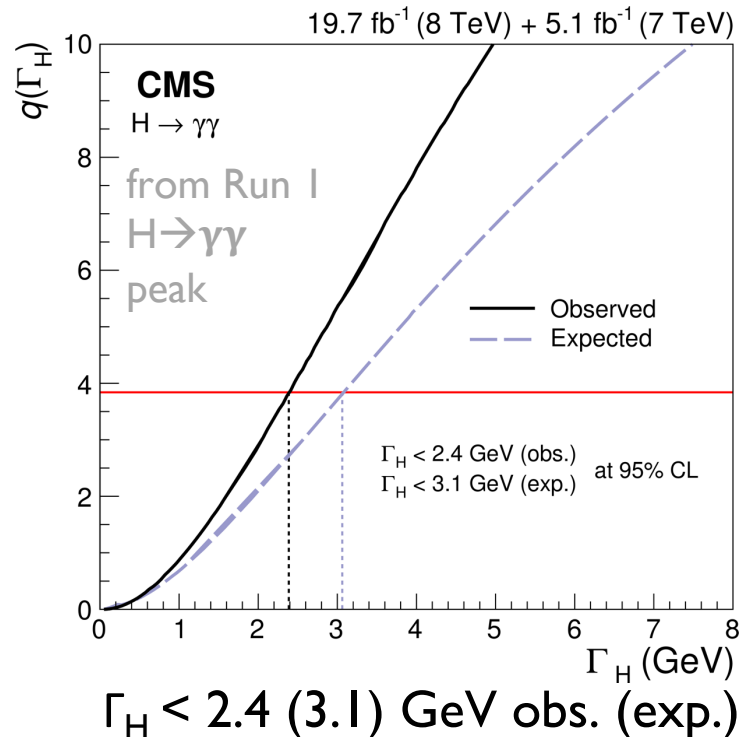

The Higgs boson as propagator: width from off-shell Higgs

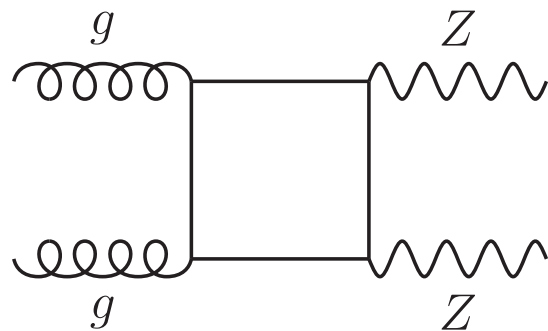
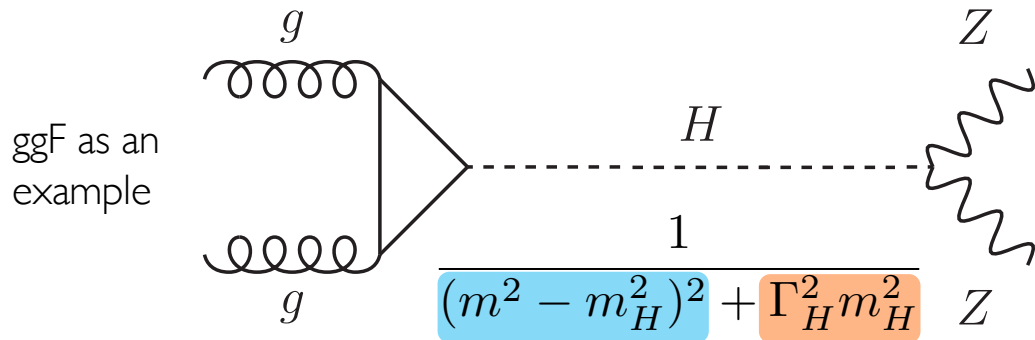

- **Interference** impacts both total cross section and $m(VV)$ line-shape
- Assuming **on-shell and off-shell couplings are equal**:

$$\frac{\mu_{\text{off-shell}}}{\mu_{\text{on-shell}}} = \frac{\Gamma}{\Gamma_{\text{SM}}}$$

$$\begin{aligned}
 vv &= gg \\
 vv &= WW, ZZ, Z\gamma, \gamma\gamma
 \end{aligned}$$

$$\sigma_{vv \rightarrow H \rightarrow 4\ell}^{\text{on-shell}} \propto \frac{g_{\text{gluon}}^2 g_V^2}{\Gamma_H} \quad \sigma_{vv \rightarrow H \rightarrow 4\ell}^{\text{off-shell}} \propto g_{\text{gluon}}^2 g_V^2$$

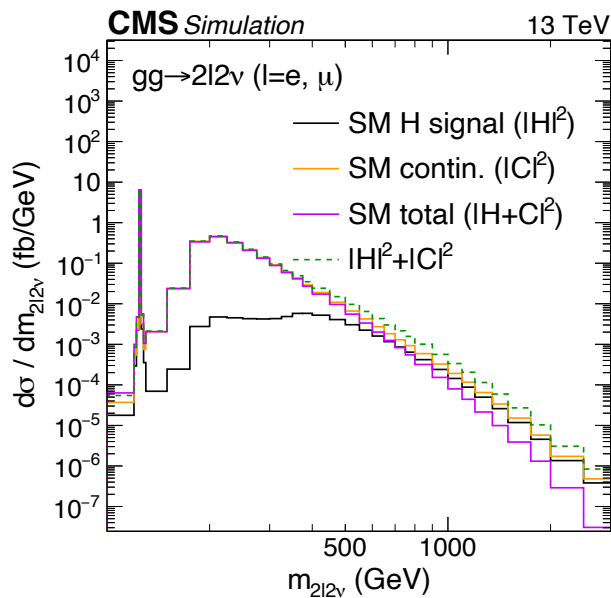

Measurements of the Higgs width from off-shell production

Measurements in **4l** and **2l2v** final states and for **different production modes**

NSBI = Neural Simulation-Based Inference

Uses NN to estimate per-event likelihood ratio of different hypotheses instead of histograms of kinematic observables as PDF

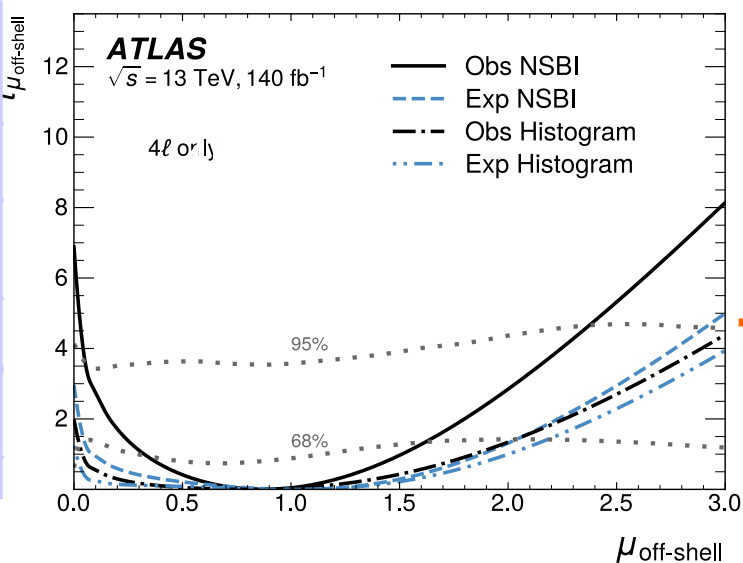

CMS
 $\Gamma_H = 3.2^{+2.5}_{-1.7} \text{ MeV}$

>3 σ evidence for off-shell H production

ATLAS
 $\Gamma_H = 4.3^{+2.7}_{-1.9} \text{ MeV}$

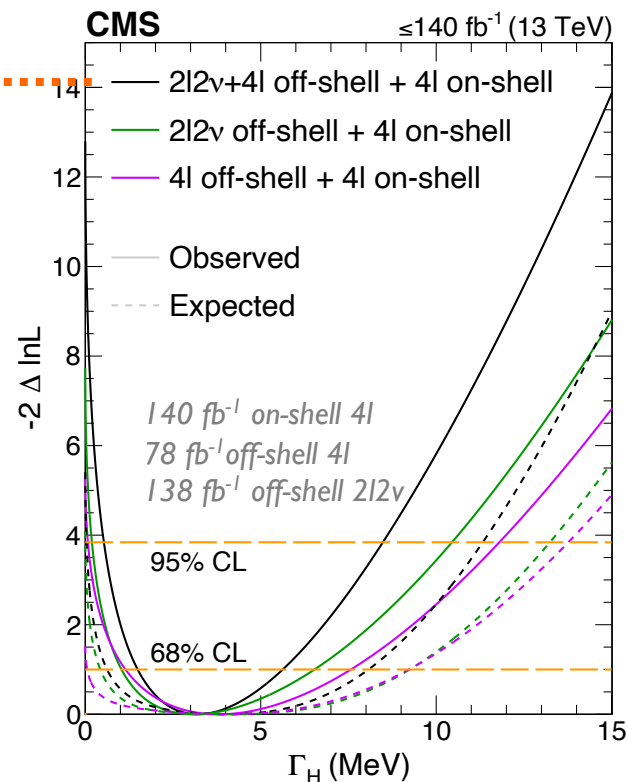

arXiv:2202.06923

Rep. Prog. Phys. 88 (2025) 057803

How well will we know the Higgs width?

- Combined ATLAS + CMS width sensitivity with 3000 fb^{-1} , based on the off-shell measurement

✓ $\Gamma_H = 4.1 \pm 0.8 \text{ MeV}$

- More conservative assumptions on theoretical uncertainties than Run 2 results
 - i.e. signal and background k-factors

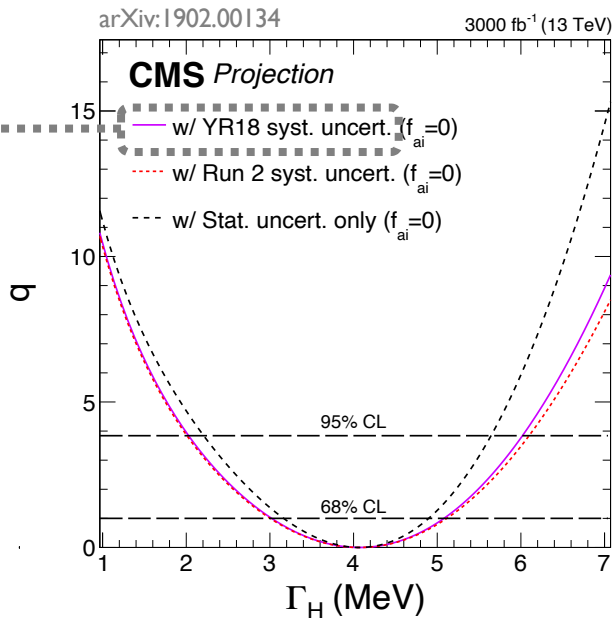

“YR18” systematics: uncertainties reduced wrt Run 2 according to the improvements expected to be reached at the end of HL-LHC e.g. theory uncertainties generally halved. See

<https://twiki.cern.ch/twiki/bin/view/LHCPhysics/HLHELHCCCommonSystematics>

Studies of the Higgs CP properties

Spin is property of the particle, CP of the coupling...

coupling to EW vector bosons

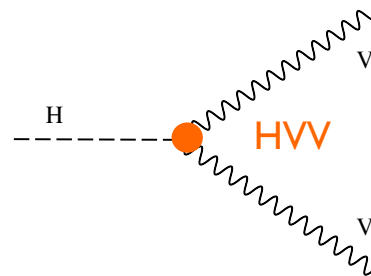
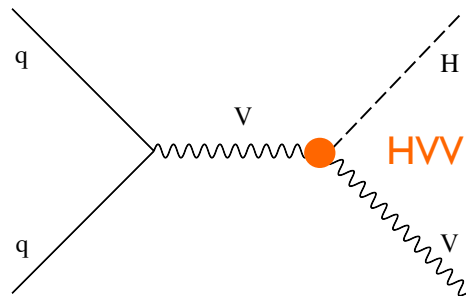
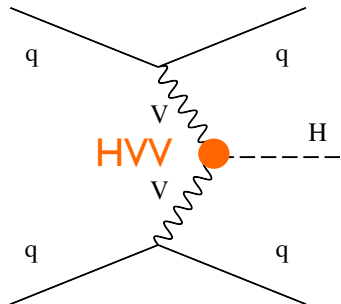

coupling to fermions

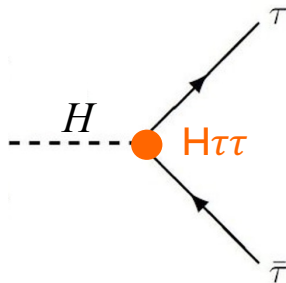
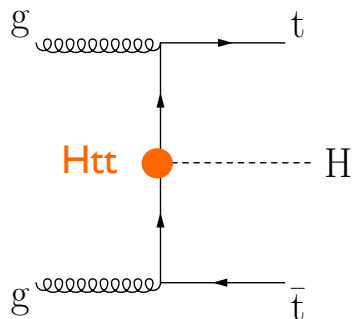

coupling to gluons

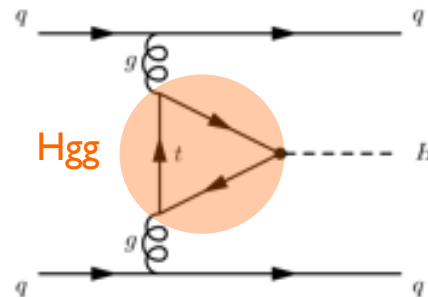

SM Higgs spin and CP properties

- SM Higgs has spin 0 and positive (even) parity ($J^{CP} = 0^{++}$)
- At the end of Run I we knew Higgs had spin 0...
 - ✓ Spin 1 and 2 hypotheses excluded at $> 99.9\%$ CL using $H \rightarrow \gamma\gamma$, $H \rightarrow ZZ^*$ and $H \rightarrow WW^*$

Example:
J=2 model
exclusions
with
 $H \rightarrow ZZ$

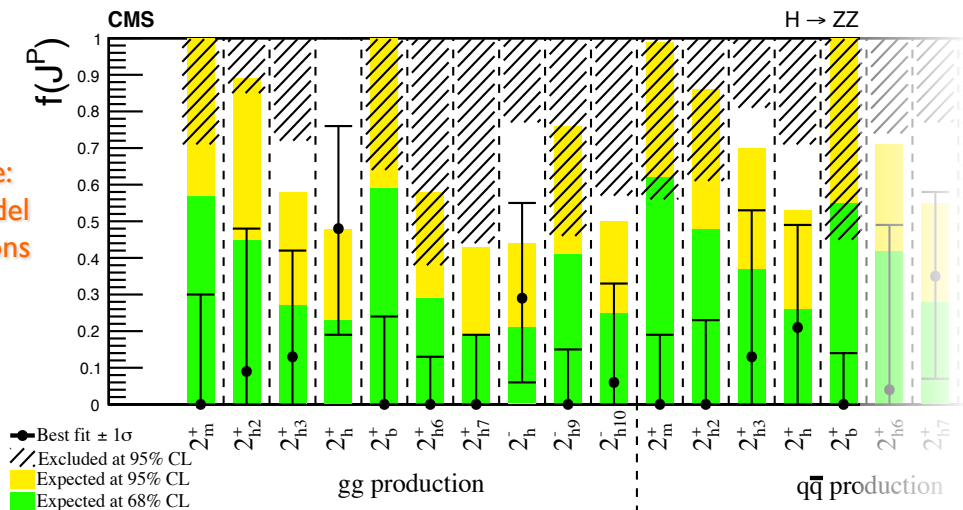

Example:
 $H \rightarrow \gamma\gamma$
spin
analysis

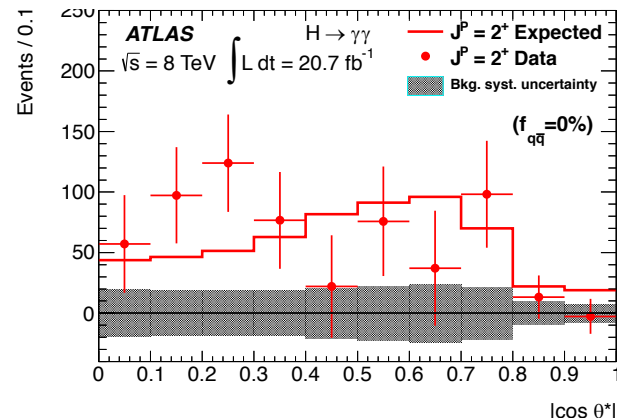
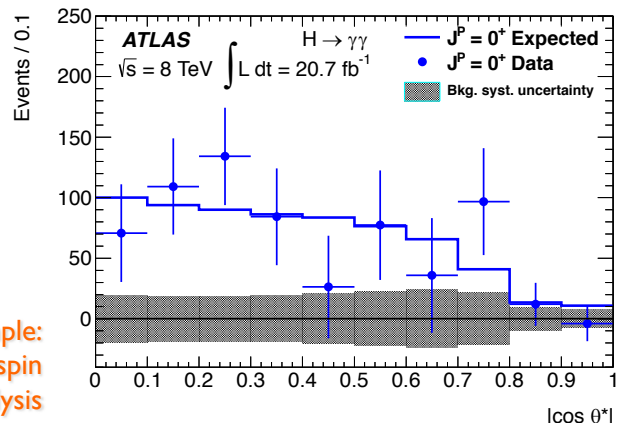

$$\cos \theta^* = \frac{\sinh(\eta_{\gamma_1} - \eta_{\gamma_2})}{\sqrt{1 + (p_T^{\gamma\gamma} / m_{\gamma\gamma})^2}} \cdot \frac{2p_T^{\gamma_1} p_T^{\gamma_2}}{m_{\gamma\gamma}^2}$$

$\gamma\gamma$ polar angle ϑ^* with respect to Z-axis in Collins-Soper frame

CP properties of Higgs-top coupling with ttH

Effective Lagrangian for Yukawa coupling to top quarks parameterized by CP-Even and CP-odd components

$$\mathcal{L}_{t\bar{t}H} = -\kappa'_t y_t \phi \bar{\psi}_t (\cos \alpha + i\gamma_5 \sin \alpha) \psi_t$$

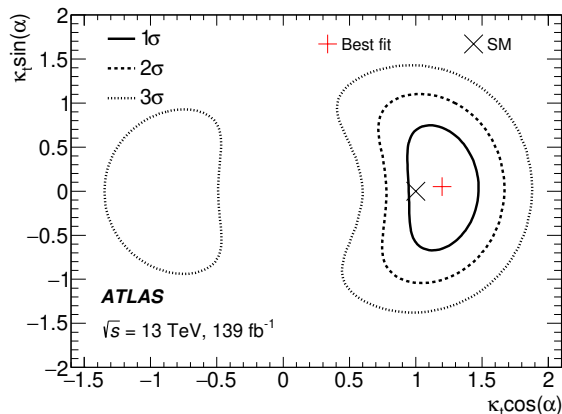
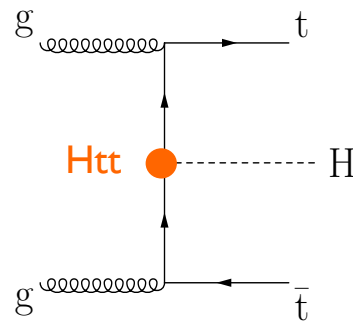

ATLAS ttH
 $H \rightarrow \gamma\gamma$

pure CP-odd
coupling

excluded at 3.9σ

Two examples:

CMS ttH
 $H \rightarrow ML$
 $+ H \rightarrow \gamma\gamma$
 $+ H \rightarrow ZZ$

pure CP-odd
coupling

excluded at 3.7σ

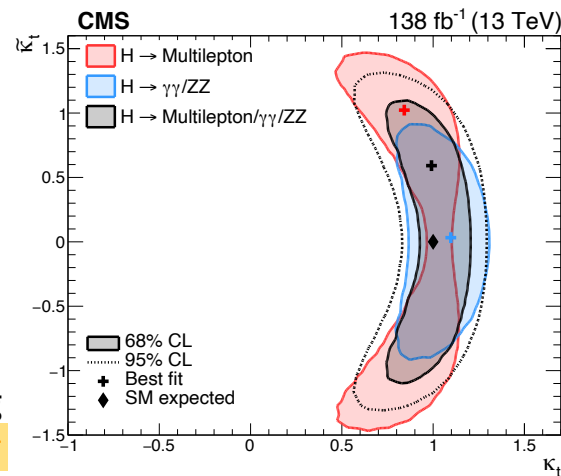

$|\alpha| > 43$ deg excluded @ 95% CL.

$$f_{CP}^{Htt} = \frac{\tilde{\kappa}_t^2}{\tilde{\kappa}_t^2 + \kappa_t^2} \quad \mathcal{A}(Hff) = \frac{m_f}{v} \bar{\psi}_f (\kappa_t + i\tilde{\kappa}_t \gamma_5) \psi_f$$

$$|f_{Htt}| = (\sin \alpha)^2 \quad |f_{Htt}| = 0.28 (< 0.55 \text{ at } 1\sigma)$$

9.



How well
do we know
the Higgs couplings?

$$|D_m \phi|^2$$
A small blackboard with a white border containing the mathematical expression $|D_m \phi|^2$ written in white chalk.

$$x_i y_{ij} x_j \phi$$
A small blackboard with a white border containing the mathematical expression $x_i y_{ij} x_j \phi$ written in white chalk.

Couplings to...

... gauge bosons

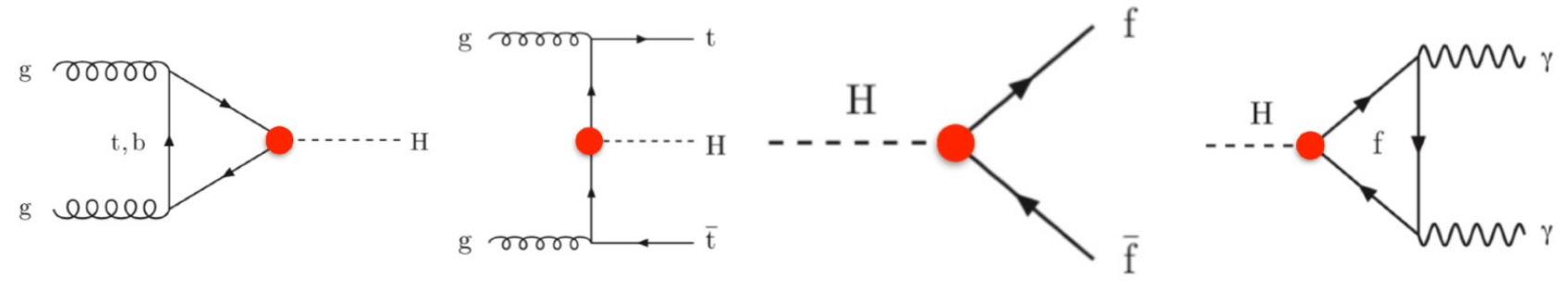
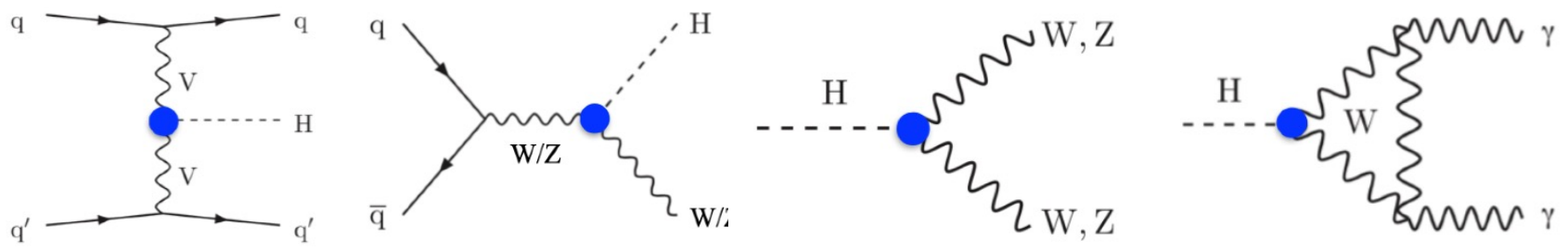

... fermions

STXS: Simplified Template Cross Sections

Stage 1.2

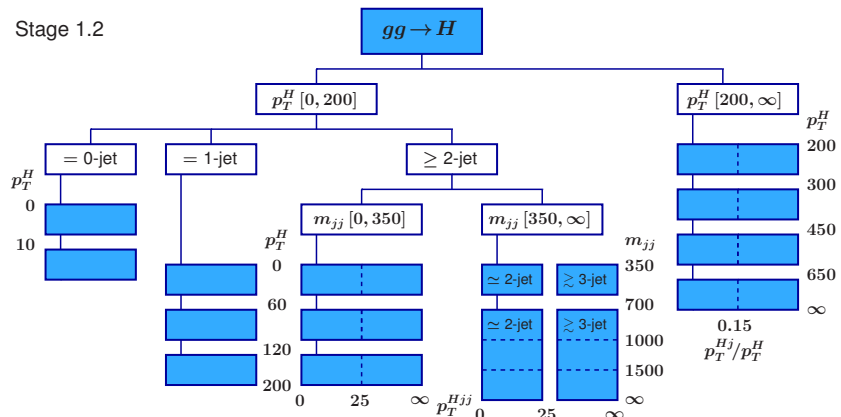

Stage 1.2

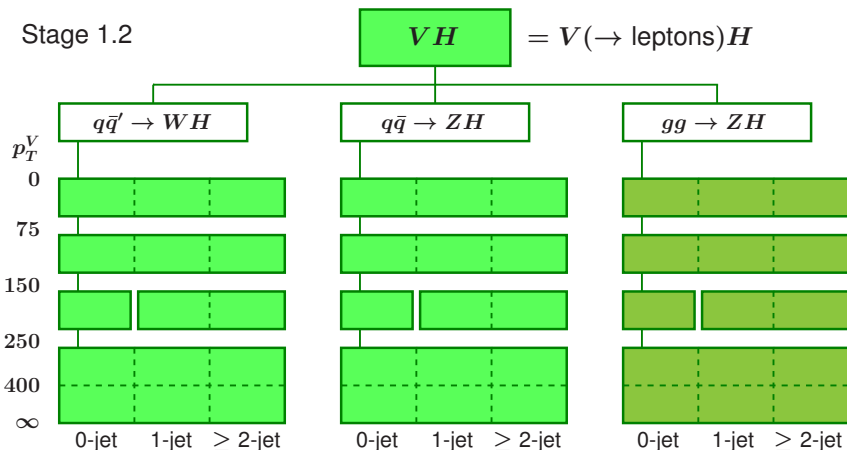

Stage 1.2

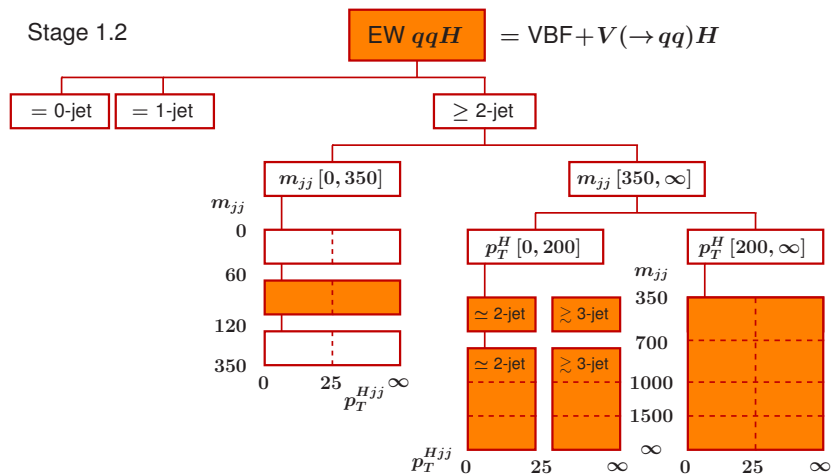

Stage 1.2

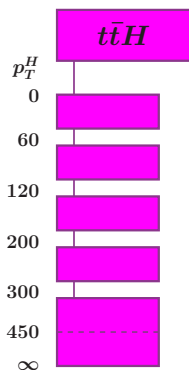

- Cross sections per production mode in different regions of phase space
 - ✓ Reduce dependency on theory
 - ✓ Allow MVA analysis
 - ✓ Exploit sensitivity of each channel specific region of phase space (designed for combination)
 - ✓ Inclusive in decays (for now)
 - ✓ Binning defined to allow better estimate of theoretical uncertainties, and easier merging when insufficient experimental sensitivity
 - ✓ Largely model-independent approach to **test for BSM deviations in kinematic distributions**

STXS at work: $H \rightarrow \gamma\gamma$

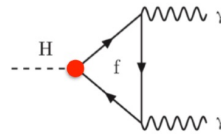

JHEP 07 (2023) 088

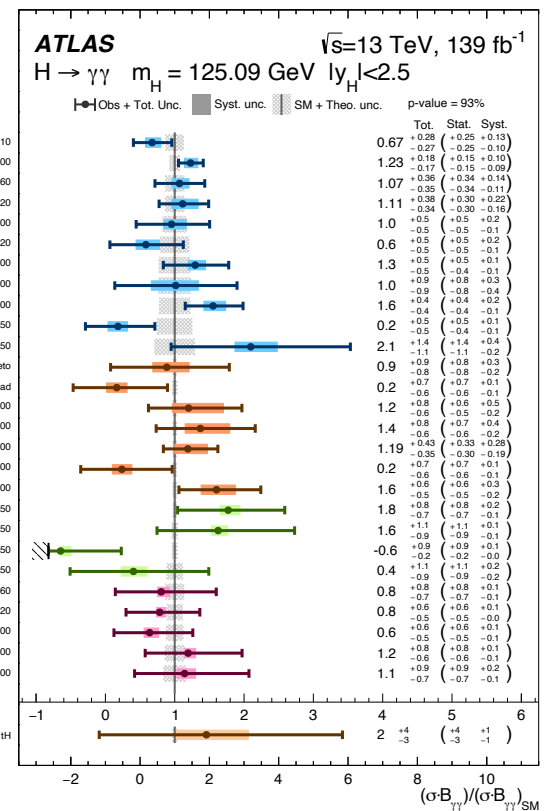
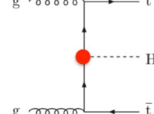
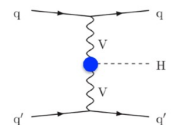
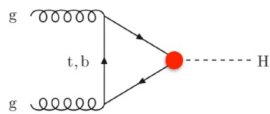
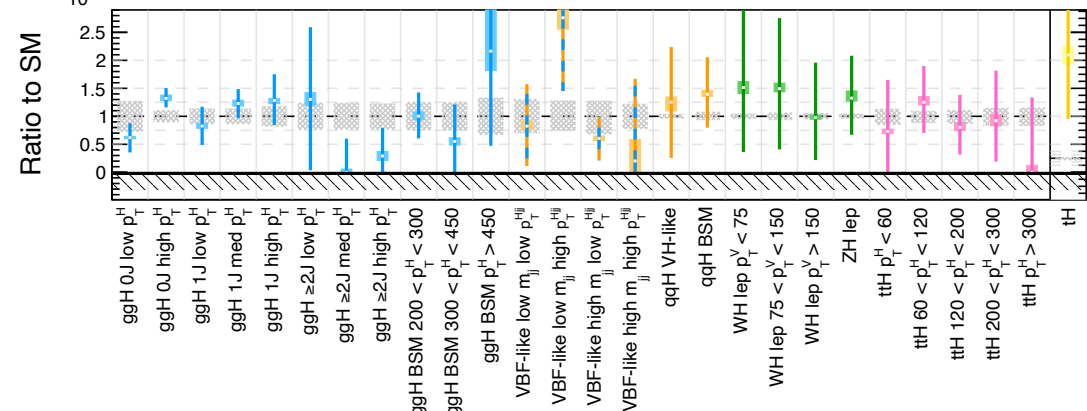
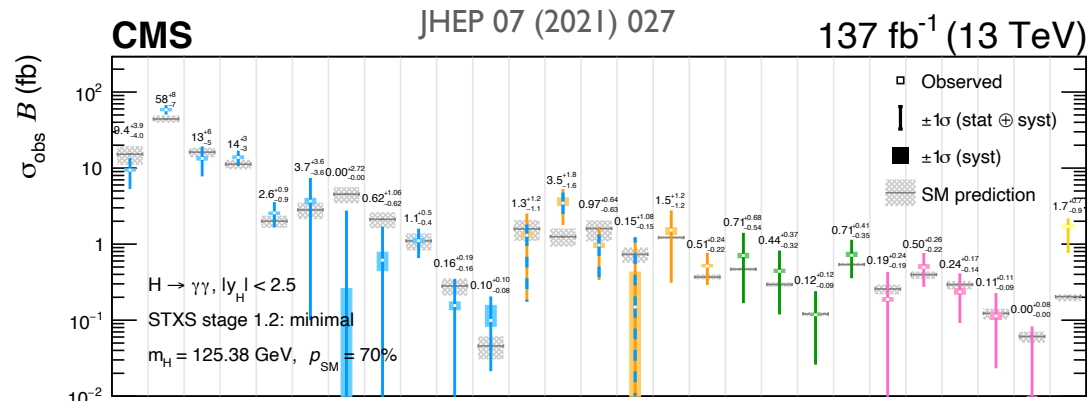

STXS at work: $H \rightarrow \gamma\gamma$

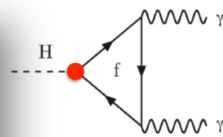

arXiv:2207.00348

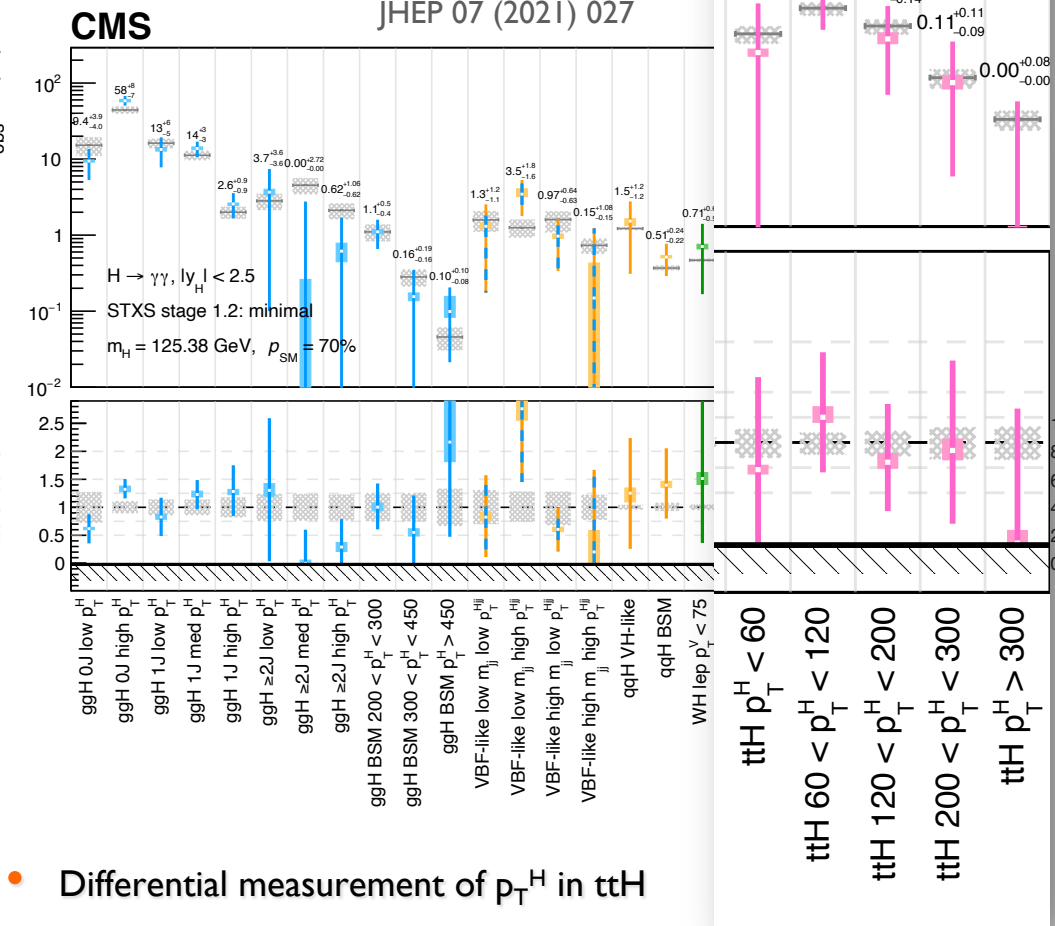

- Differential measurement of p_T^H in $t\bar{t}H$

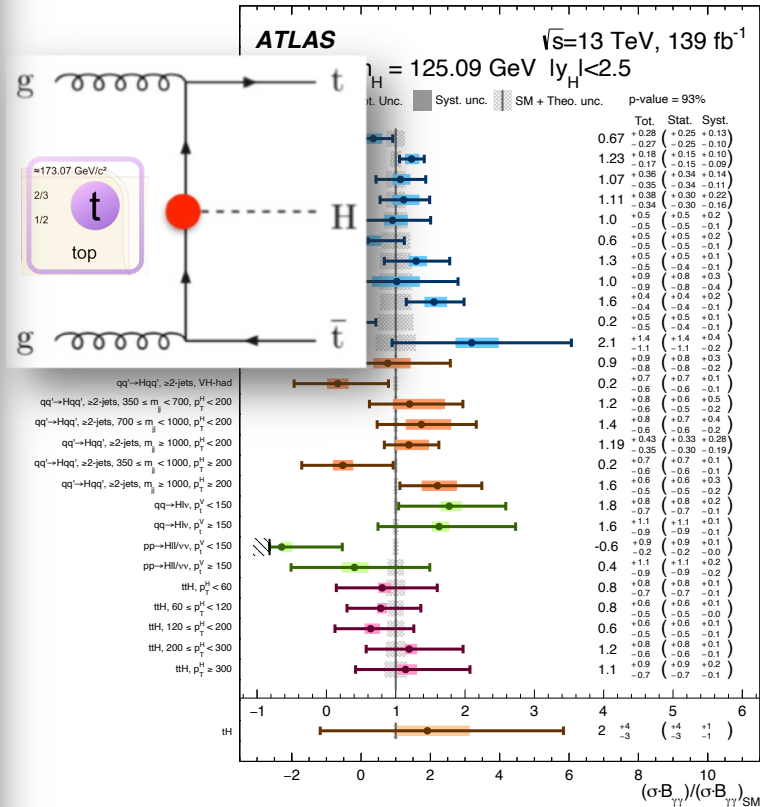

STXS at work: $H \rightarrow \gamma\gamma$

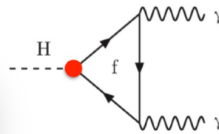

arXiv:2207.00348

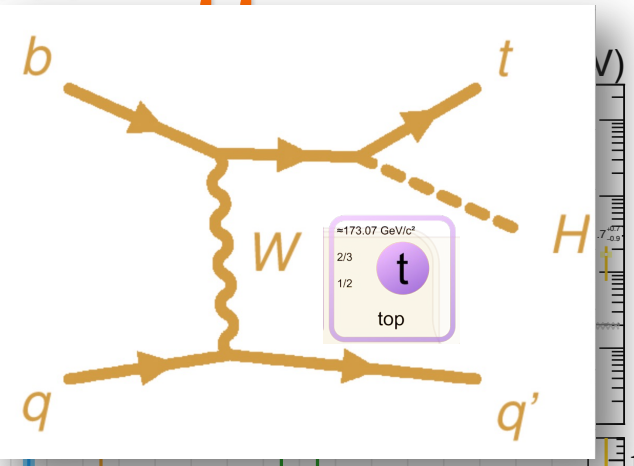
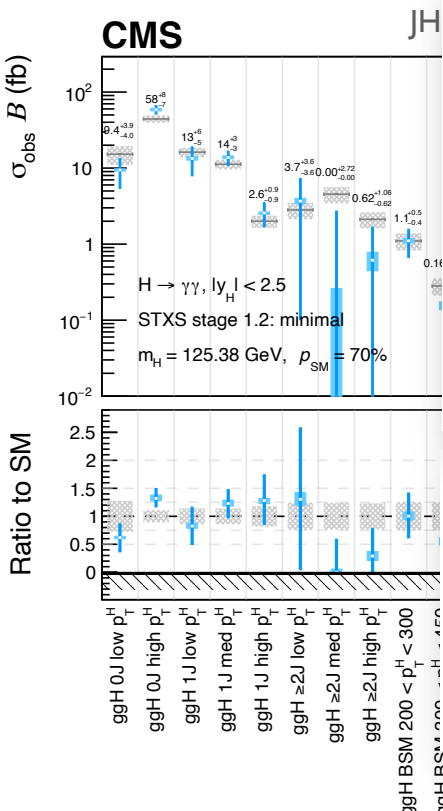
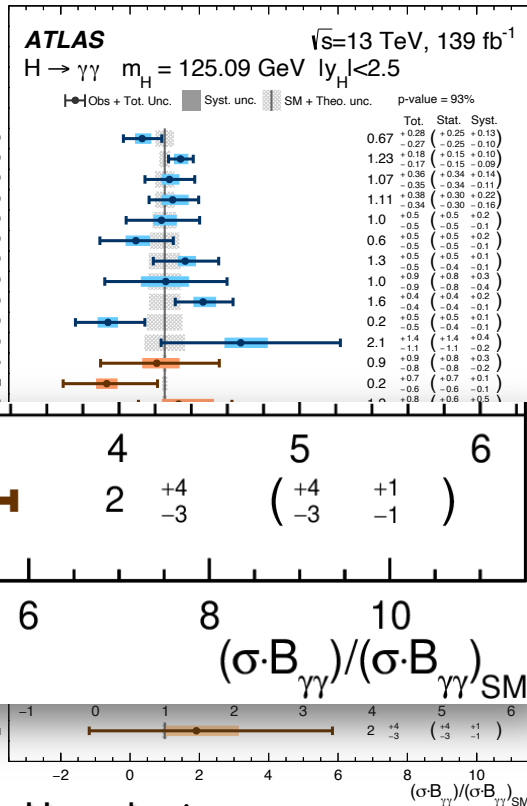

- gg→H, 0-jet, $p_T^H < 10$
- gg→H, 0-jet, $10 \leq p_T^H < 200$
- gg→H, 1-jet, $p_T^H < 60$
- gg→H, 1-jet, $60 \leq p_T^H < 120$
- gg→H, 1-jet, $120 \leq p_T^H < 200$
- gg→H, ≥2-jets, $m_j < 350, p_T^H < 120$
- gg→H, ≥2-jets, $m_j < 350, 120 \leq p_T^H < 200$
- gg→H, ≥2-jets, $m_j \geq 350, p_T^H < 200$
- gg→H, 200 ≤ p_T^H < 300
- gg→H, 300 ≤ p_T^H < 450
- gg→H, p_T^H ≥ 450
- qq'→Hqq', s1-jet and VH-Veto
- qq'→Hqq', ≥2-jets, VH-had

- Closing in on tH production
- ✓ ~10 × σ_{tH}^{SM} excluded at 95% CL

H \rightarrow $\gamma\gamma$ as an example: Run 2 vs HL-LHC

- While STXS measurement remains main current goal, traditional “production-mode” results (a.k.a. “Stage 0” STXS) still measured by more powerful decay channels and in combination
- Already at Run 2 some measurement **limited by systematics: more and more true in the future!**

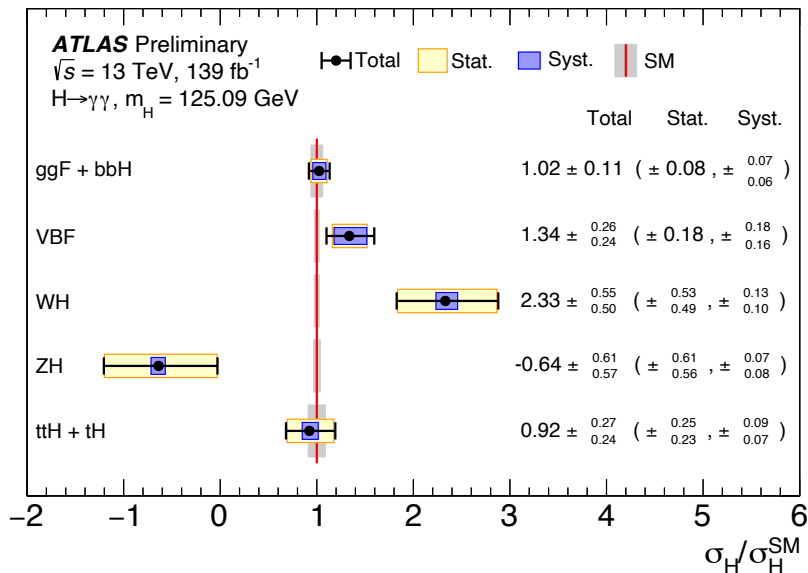

ATLAS-CONF-2020-026

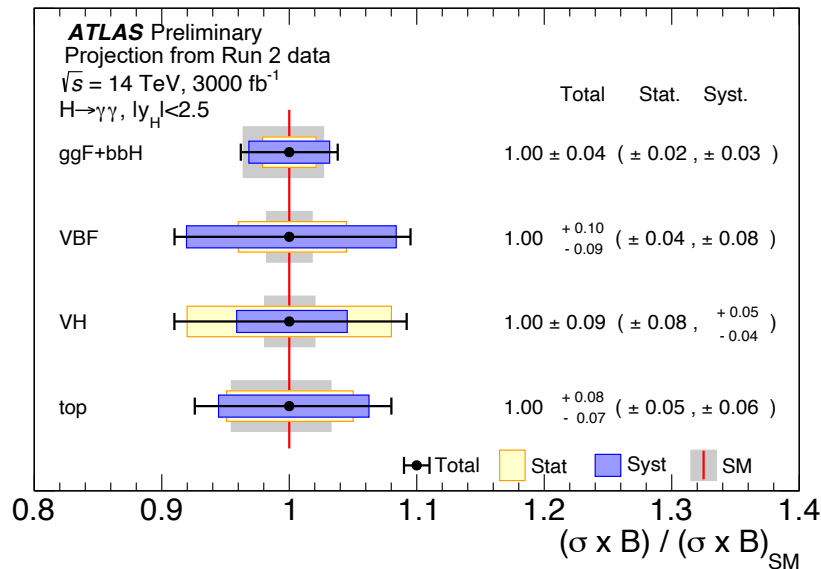

arXiv:1902.00134

10.

zoom on Higgs coupling to fermions

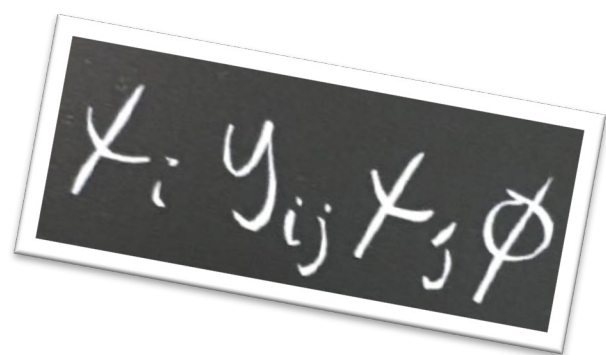

PDG 2012

$b\bar{b}$
 $\tau^+\tau^-$

possibly seen
possibly seen

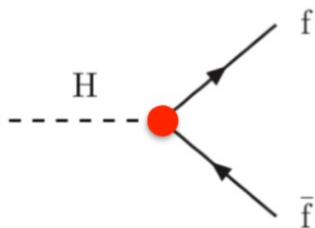

PDG 2022

$c\bar{c}$ Final State = 37 ± 20
 $b\bar{b} = 0.98 \pm 0.12$
 $\mu^+\mu^- = 1.19 \pm 0.34$
 $\tau^+\tau^- = 1.15^{+0.16}_{-0.15}$
 $Z\gamma < 3.6, \text{ CL} = 95\%$
 $\gamma^*\gamma$ Final State = 1.5 ± 0.5
 $t\bar{t}H^0$ Production = 1.10 ± 0.18



Why is Yukawa interaction important?

In SM Yukawa interaction between Higgs and fermions gives fermions their mass...

- **Why is elementary mass important? Two ideas...**

- ✓ Mass of quark u and d is responsible for difference of mass between neutron and proton, thus of proton stability, thus of existence of hydrogen atoms...

proton (up+up+down): $2.2 + 2.2 + 4.7 + \dots = 938.3$ MeV

neutron (up+down+down): $2.2 + 4.7 + 4.7 + \dots = 939.6$ MeV

- ✓ Mass of electron determines Bohr radius, thus dimensions of atoms, thus all chemistry

$$a_0 = \frac{4\pi\epsilon_0 \hbar^2}{m_e e^2} = \frac{\hbar}{m_e c \alpha}$$



$$m_i = -\frac{y_i v}{\sqrt{2}} \quad v = \frac{\mu}{\sqrt{\lambda}}$$

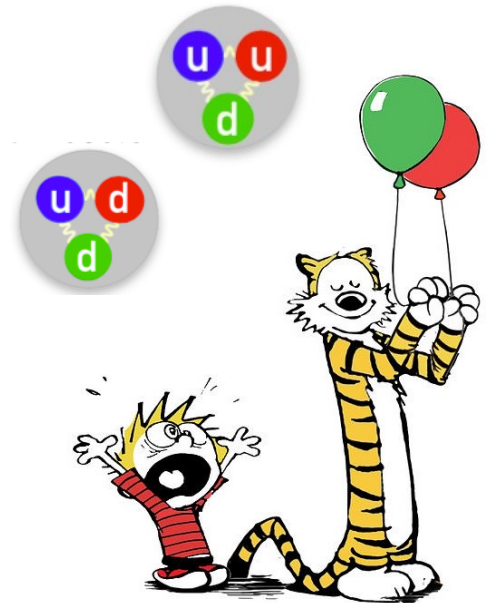

Coupling to top quark: direct observation of $t\bar{t}H$ in 2018!

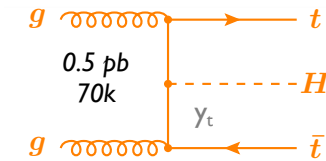
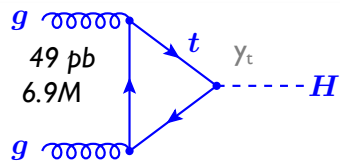

CMS (Run I + 36 fb^{-1} Run 2): 5.2 σ (4.2 σ exp)

ATLAS: (Run I + 36-80 fb^{-1} Run 2): 6.3 σ (5.1 σ exp)

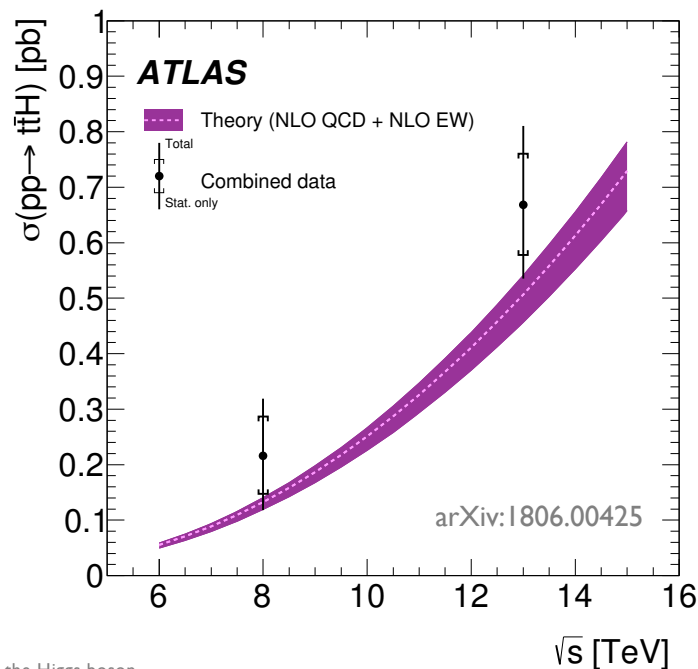
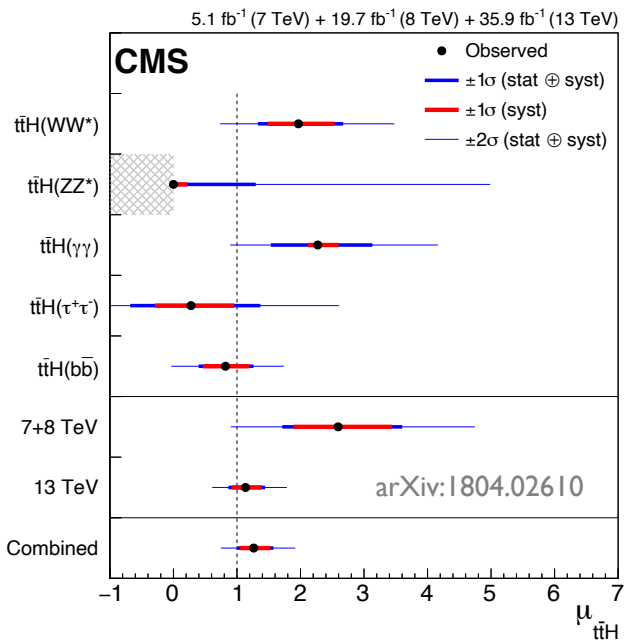

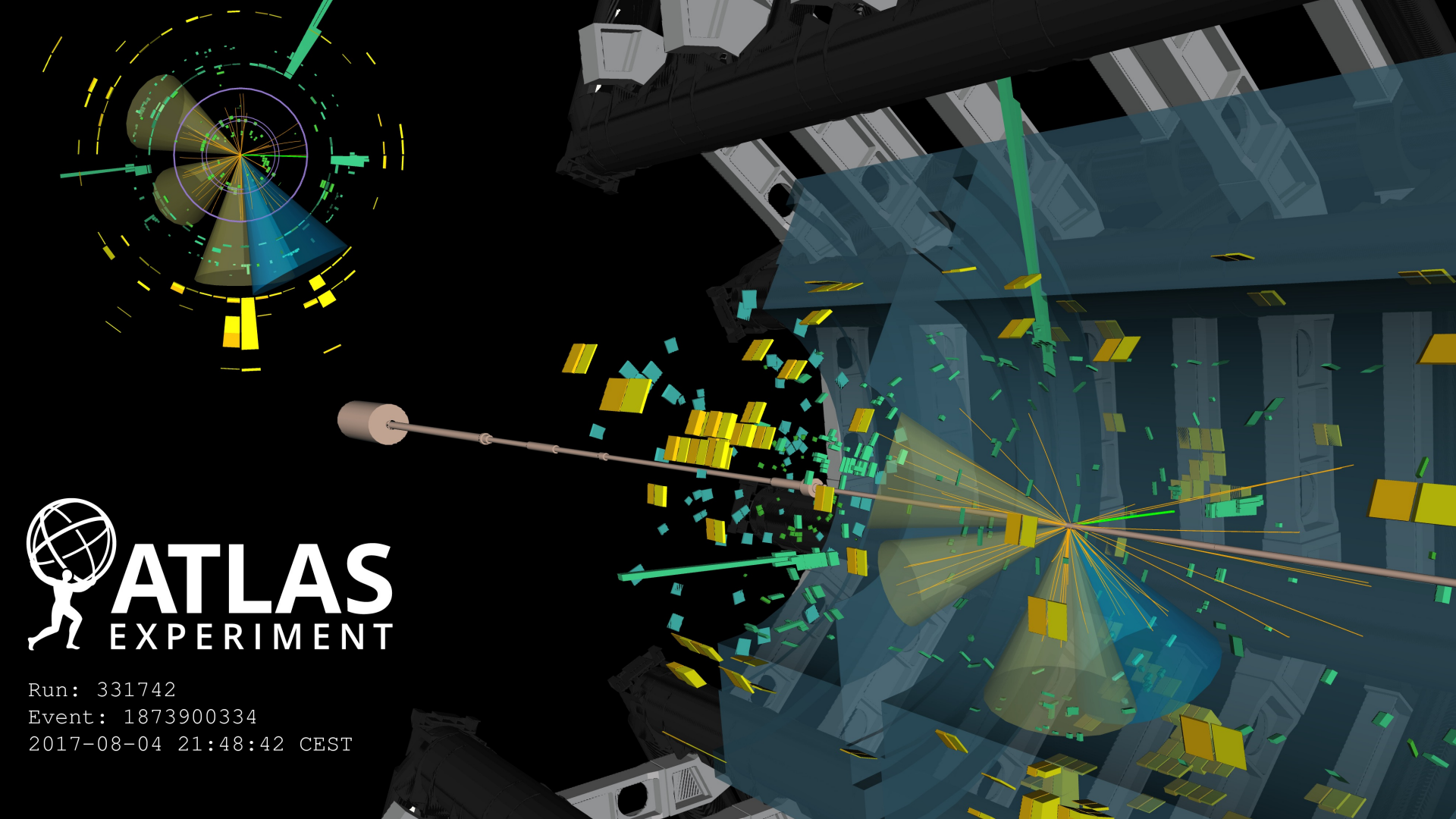

ATLAS
EXPERIMENT

Run: 331742
Event: 1873900334
2017-08-04 21:48:42 CEST

Coupling to bottom quark: observation of VH/H → bb in 2018!

- Difficult channel despite large BR(58%) due to large backgrounds

✓ VH production most sensitive → **Observation in 2018!**

- ATLAS: 5.4σ (5.5σ) ATLAS: arXiv:1808.08238
- CMS: 5.5σ (5.6σ) CMS: arXiv:1808.08242

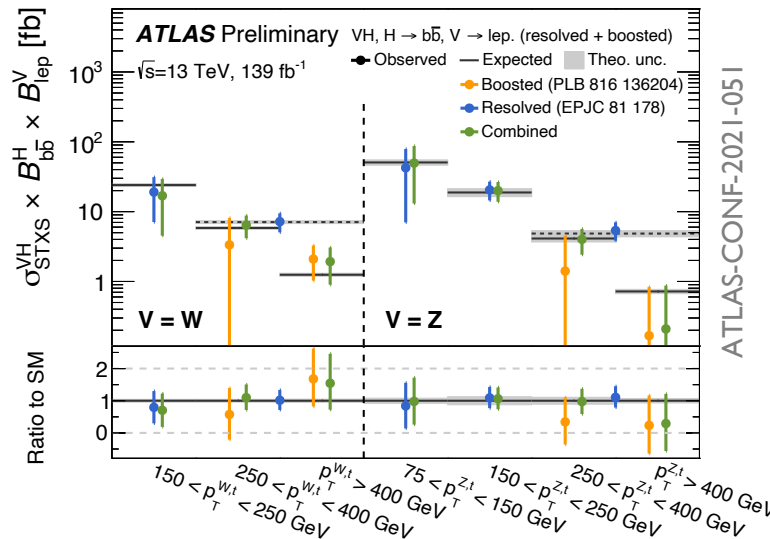
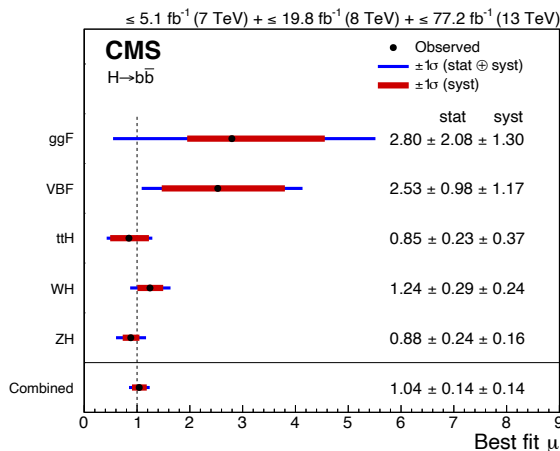
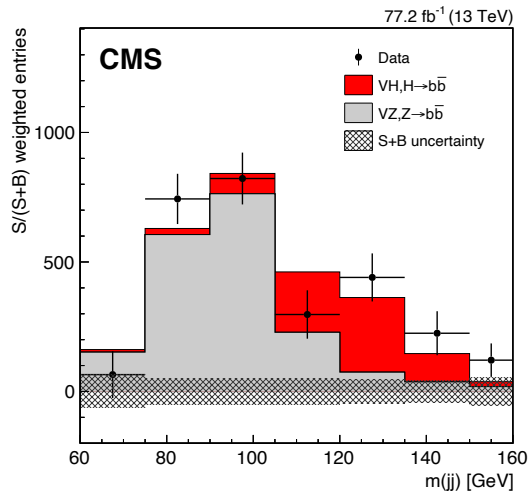
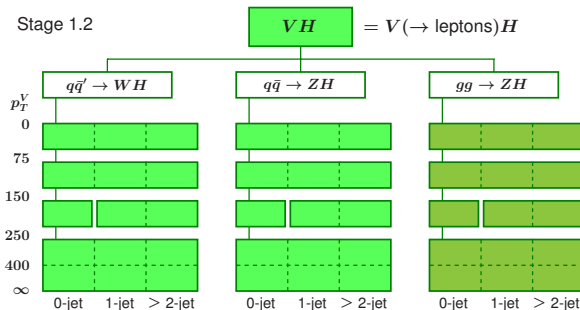
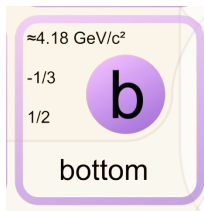

ATLAS-CONF-2021-051

Coupling to 3rd generation leptons: $H \rightarrow \tau\tau$

- Observation already in Run I ATLAS+CMS coupling combination
- Now more precise measurements, bringing sensitivity to regions of the phase space less well measured by e.g. $H \rightarrow \gamma\gamma$ and $H \rightarrow 4l$
 - ✓ i.e. ggF high p_T^H and especially VBF

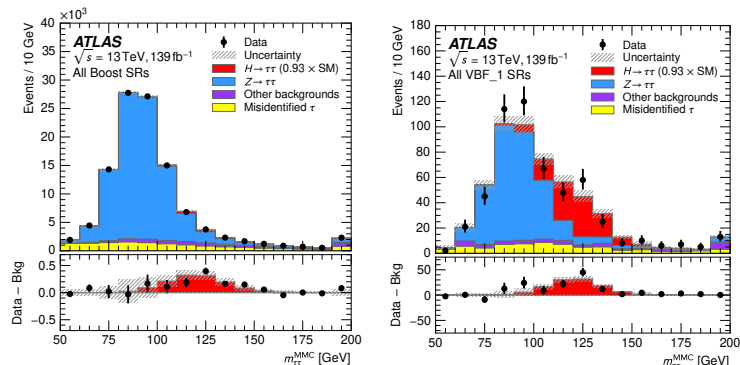

CMS-PAS-HIG-19-010

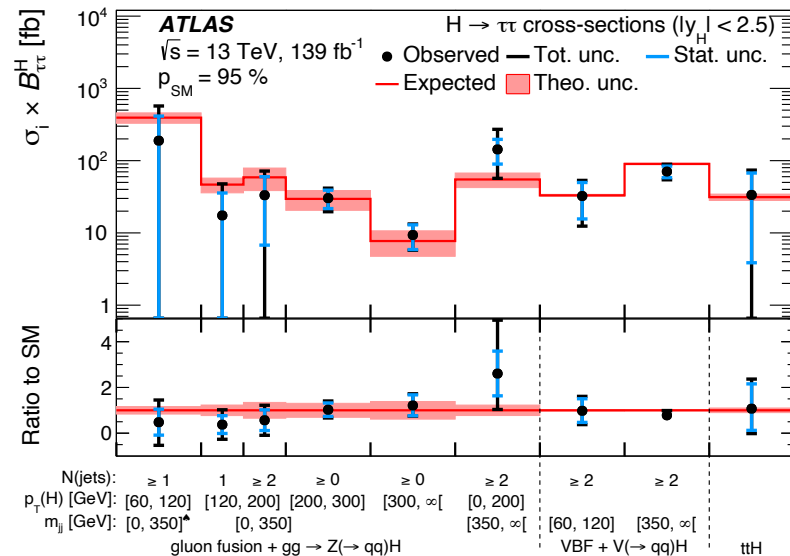
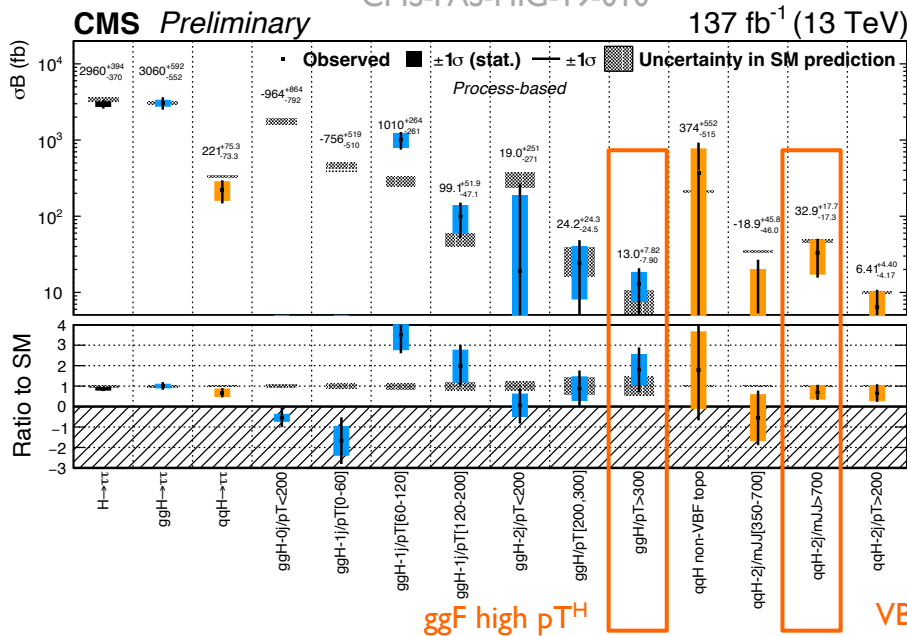

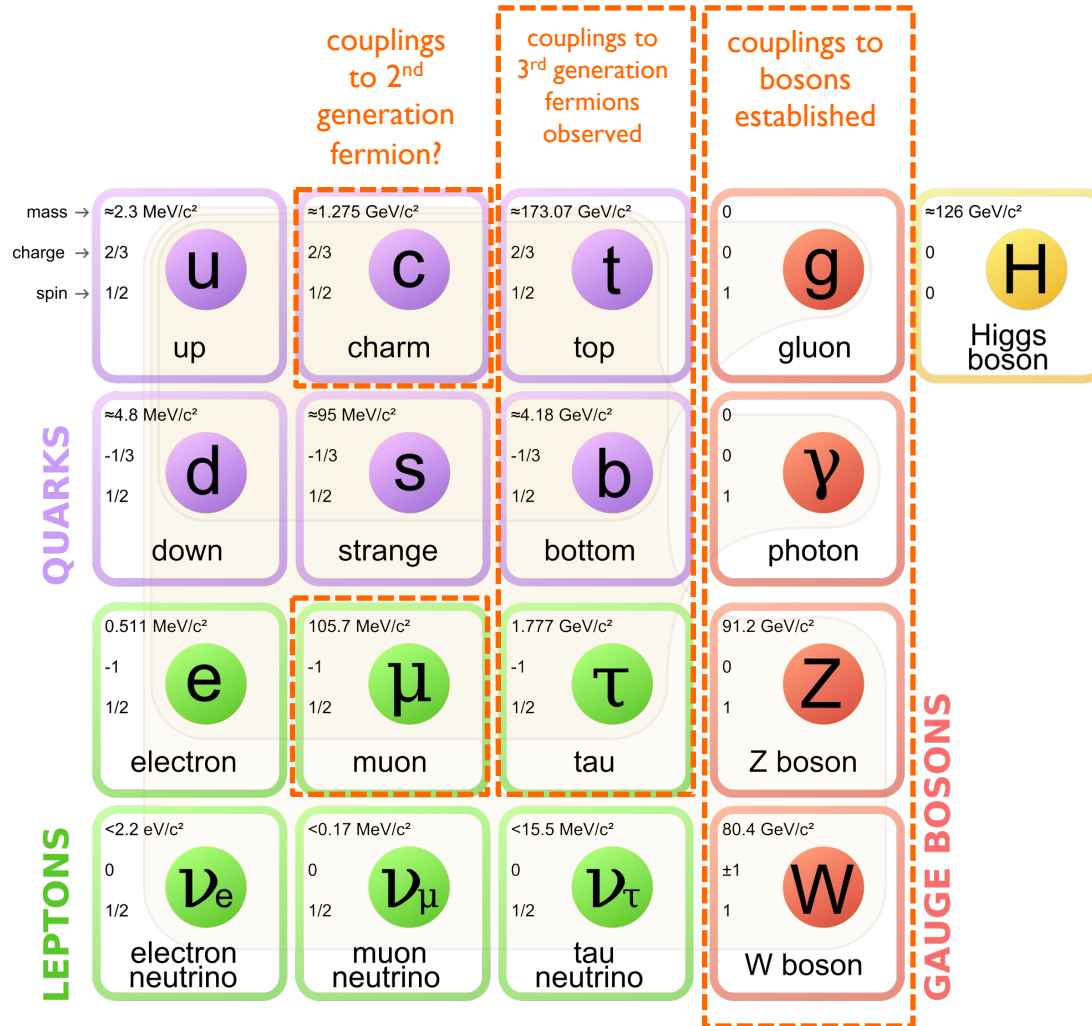

Is the Higgs boson responsible for the EW symmetry breaking also responsible for the masses of fermions?

Is the Higgs boson responsible for the masses of all fermions?

Coupling to 2nd gen. leptons: first $H \rightarrow \mu\mu$ evidence in 2020!

- $H \rightarrow \mu\mu$ very rare ($\text{BR} \sim 2 \cdot 10^{-4}$) with large resonant background from $DY \rightarrow \mu\mu$ ($S/B \sim 0.1\%$)

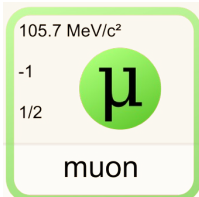

JHEP 01 (2021) 148

137 fb⁻¹ (13 TeV)

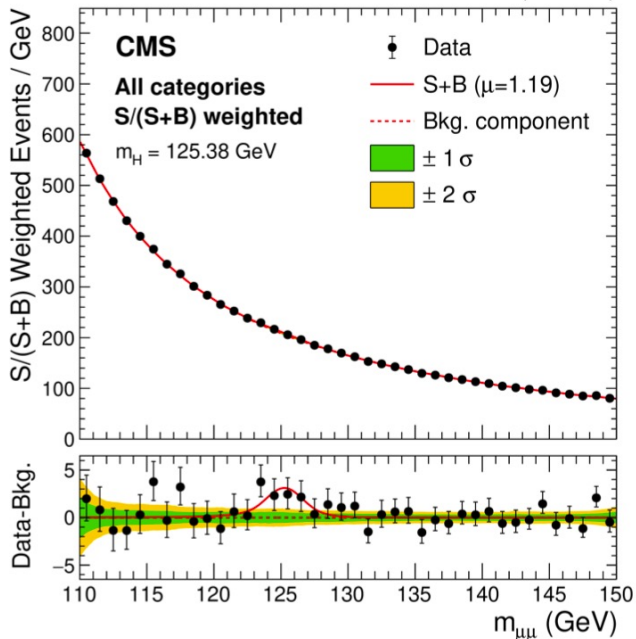

$$\mu = 1.2 \pm 0.2$$

Significance: **3.0 σ** (2.5 expected)

Phys. Rev. Lett. 135 (2025) 231802

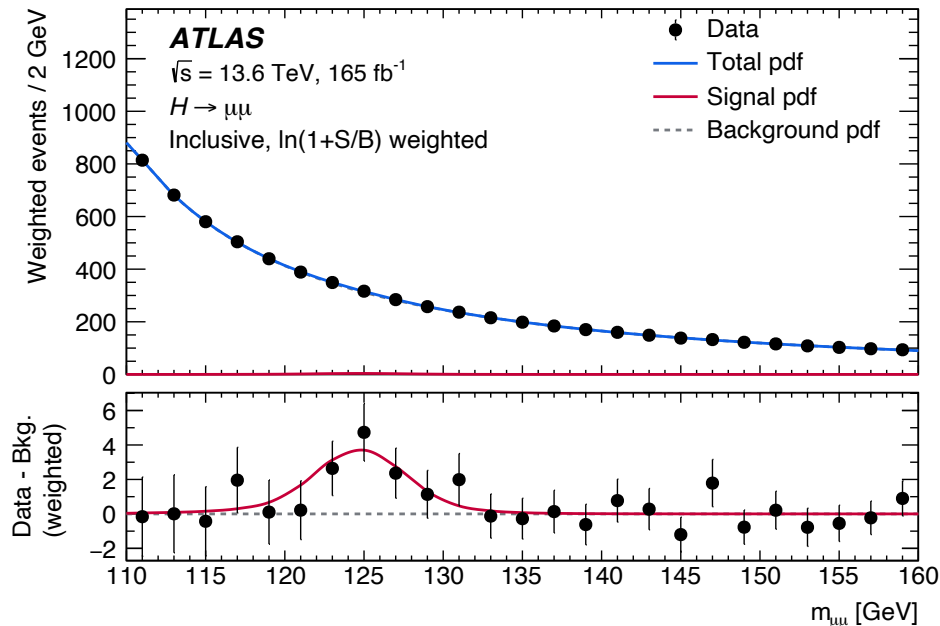

$$\mu = 1.4 \pm 0.4$$

Significance: **3.4 σ** (2.5 expected)

The next frontier: coupling to 2nd generation quarks $H \rightarrow c\bar{c}$

- Very challenging channel: large backgrounds from multi-jets
 - ✓ c-tagging needed to discriminate $H \rightarrow b\bar{b}$

$$\mu_{VH(c\bar{c})}(\kappa_c) = \frac{\kappa_c^2}{1 + B_{H \rightarrow c\bar{c}}^{\text{SM}}(\kappa_c^2 - 1)}$$

Eur. Phys. J. C 82 (2022) 717

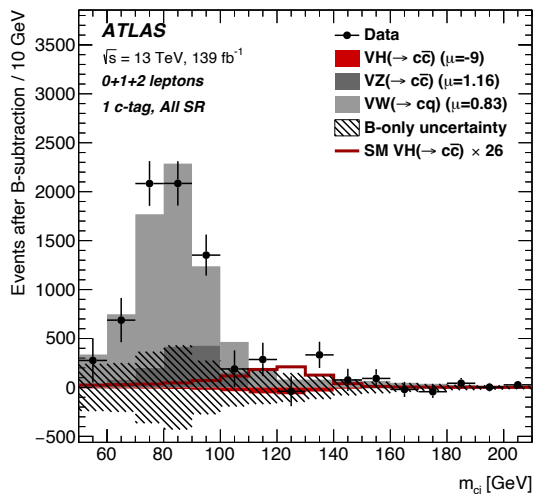

VZ,VW: 3.8 σ for VW(\rightarrow cq)

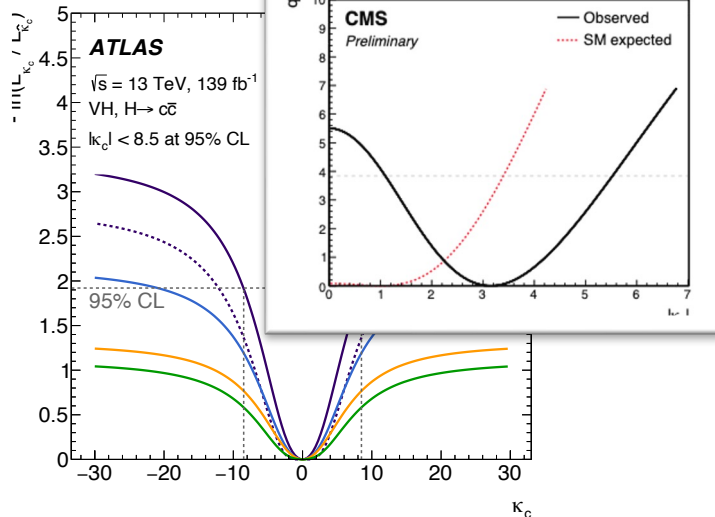

limits on κ_c coupling

ATLAS: $\kappa_c = \sigma/\sigma_{\text{SM}} < 8.5$ (12.4 exp.)

CMS: $1.1 < \kappa_c < 5.5$ (< 3.4 exp.)

Phys. Rev. Lett. 131 (2023) 061801

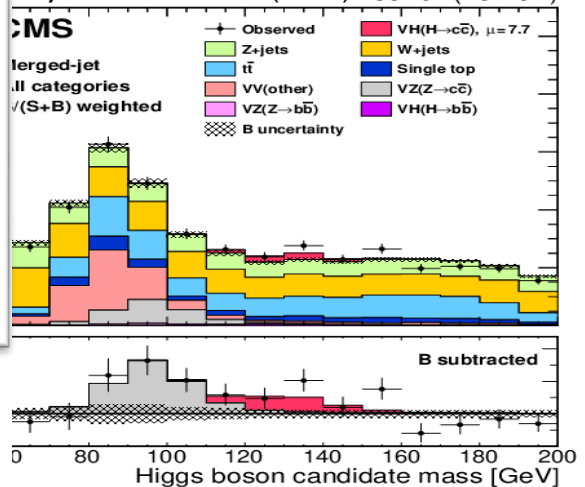

$Z \rightarrow c\bar{c}$: 5.7 σ

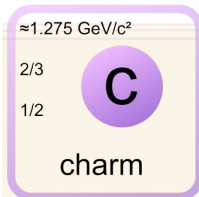

Will we observe $H \rightarrow cc$ in the future?

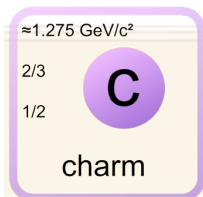

- Extrapolations to HL-LHC luminosity
 - ✓ Sensitivity to k_c (and k_b) from ATLAS $VH/H \rightarrow cc$ and $VH/H \rightarrow bb$ analyses
 - Sensitivity to k_c and k_b from CMS p_T^H differential measurements

ATL-PHYS-PUB-2021-039

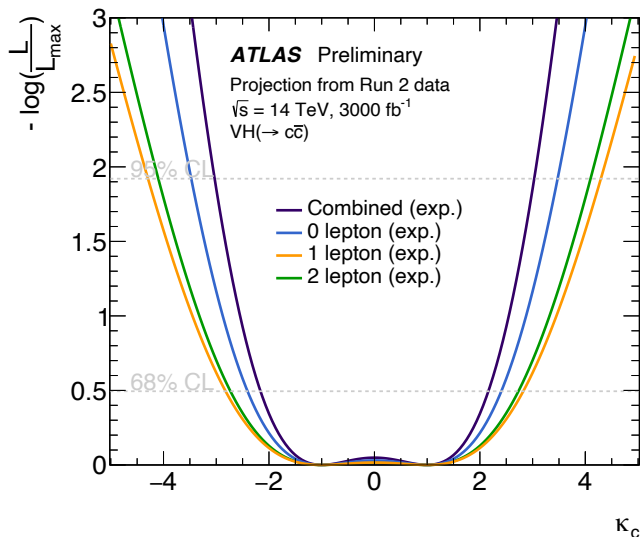

$\kappa_c = \sigma/\sigma_{\text{SM}} < 3 \text{ @ } 95\% \text{ CL}$

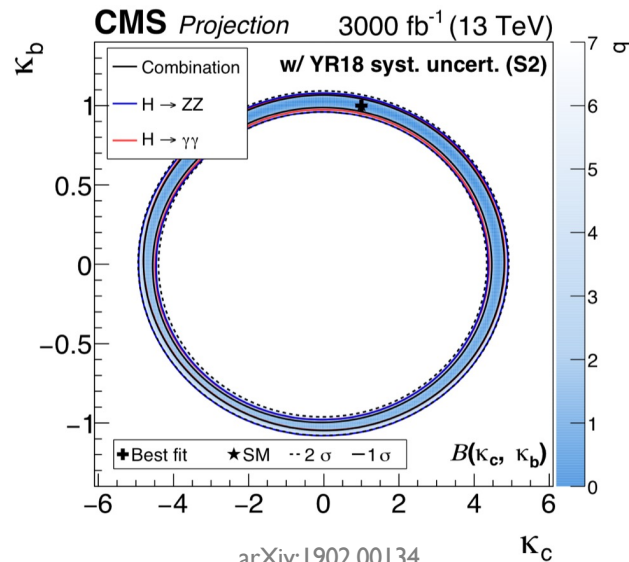
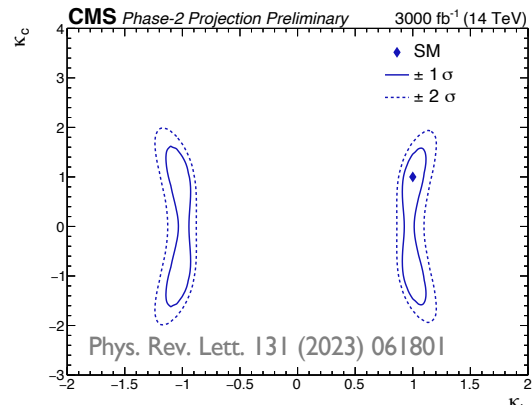
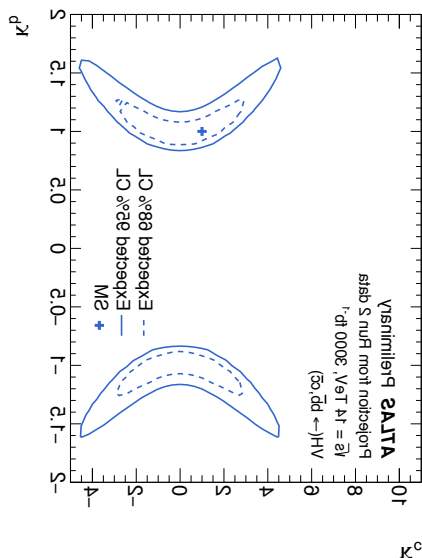

11.

One for all,
all for one!



The Standard Model rules (over 3 order of magnitudes)!

Nature 607 (2022) 52

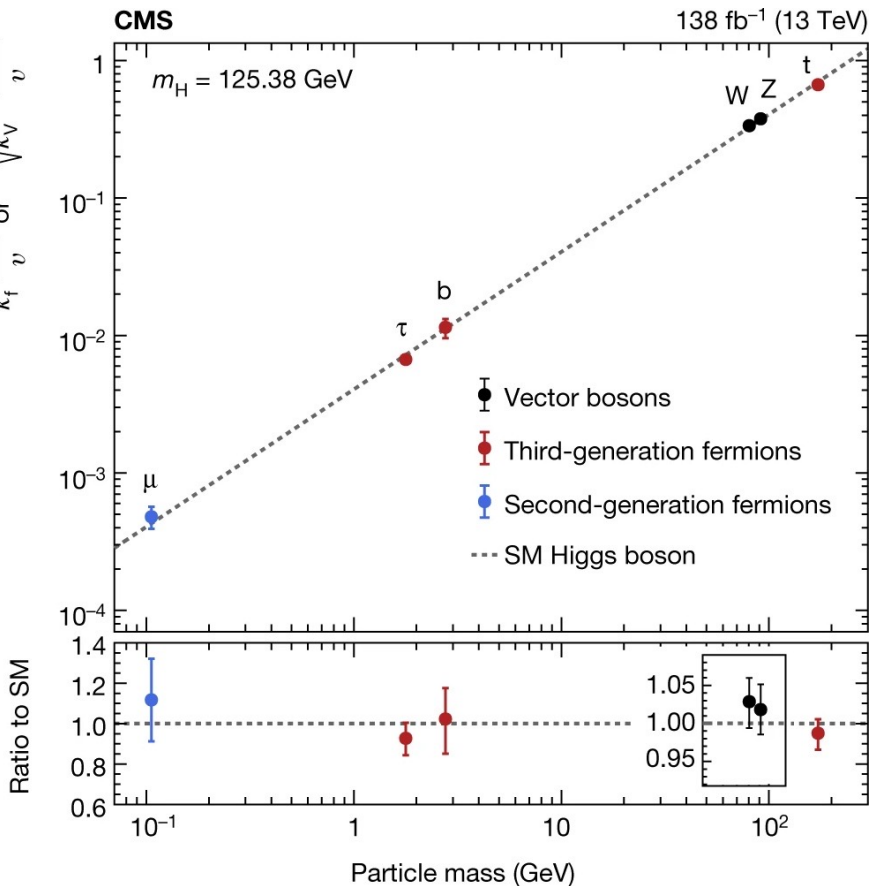
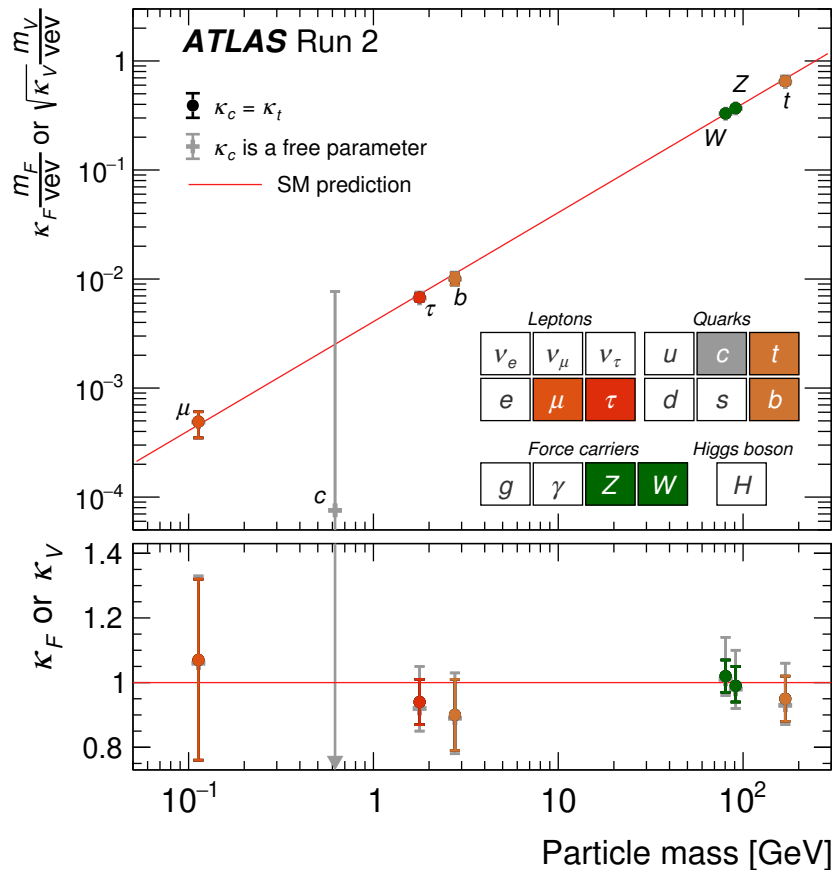

Nature 607 (2022) 60

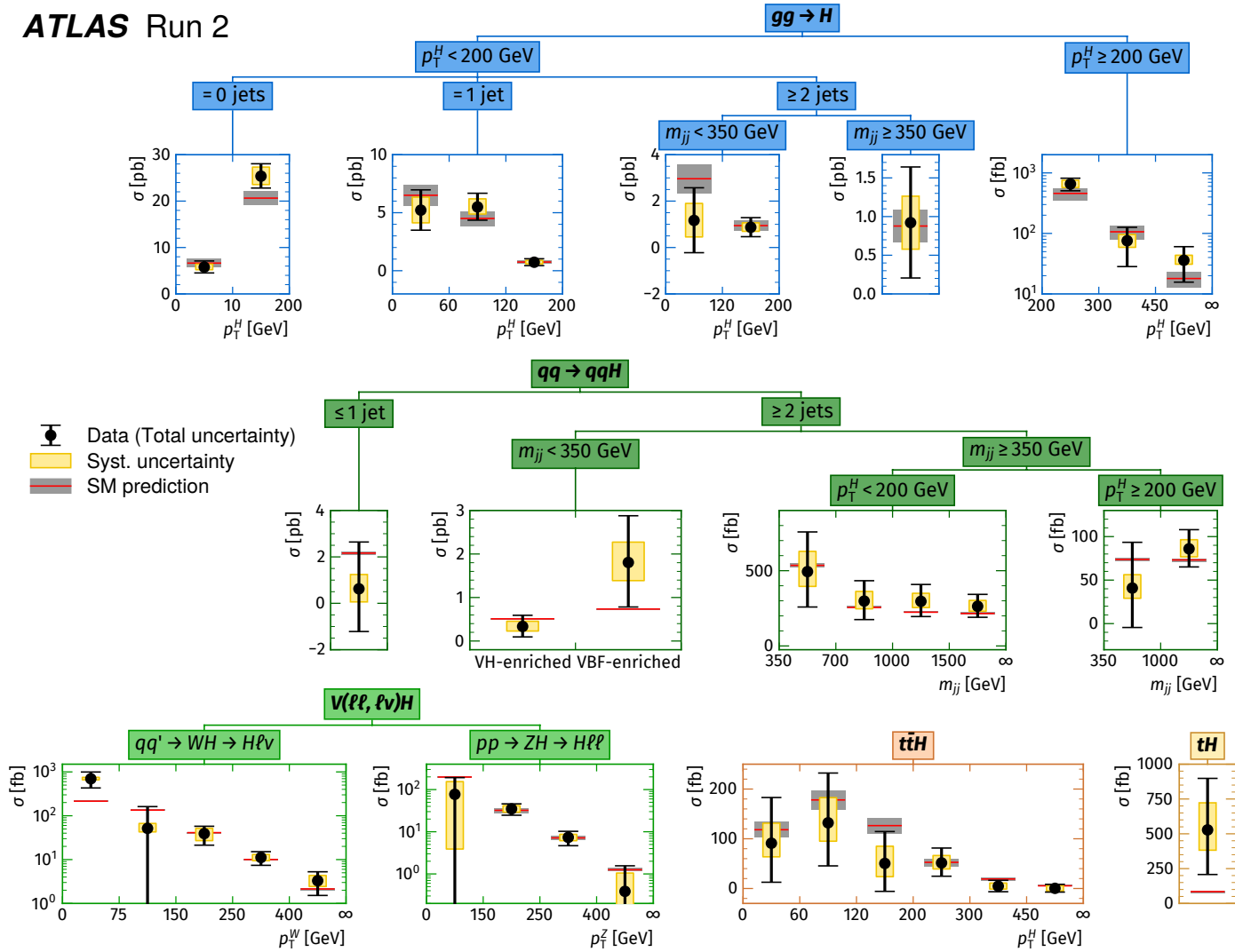

How well do we know the Higgs couplings?

- **Higgs couplings known to ~6-15%**
 - ✓ Some channel not included yet, or with partial statistics
 - ✓ Expect more improvements, from use of Run 3 data and ATLAS+CMS combination

$$\kappa_j^2 = \sigma_j / \sigma_j^{\text{SM}}$$

$$\kappa_j^2 = \Gamma^j / \Gamma_{\text{SM}}^j$$

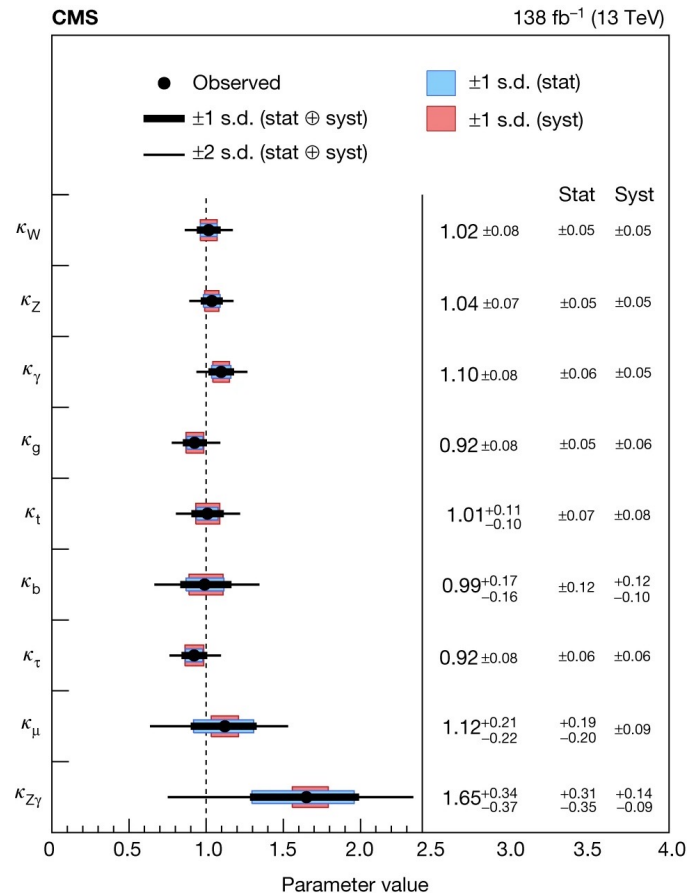
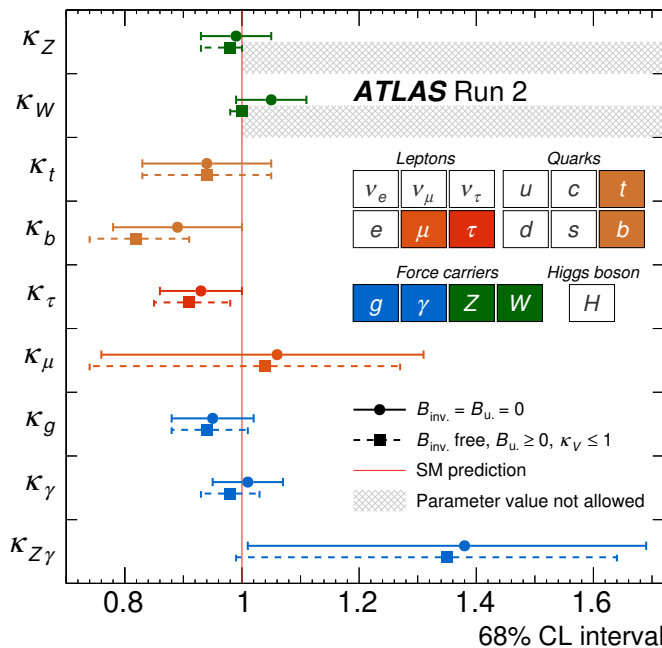

How well will we know the Higgs couplings?

- **2-4% precision** expected with $2 \times 3000 \text{ fb}^{-1}$

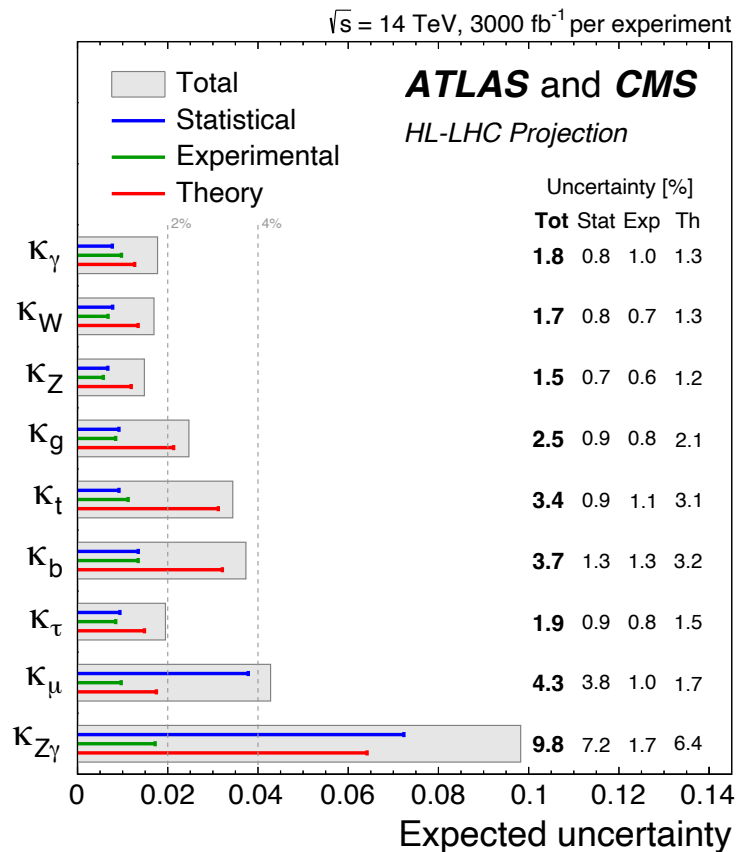

arXiv:1902.00134

12.

Can the
Higgs boson
tell us something
about new phenomena?



Can Higgs properties constrain BSM phenomena today?

- Most recent approach: **Effective Field Theory (EFT)** interpretation

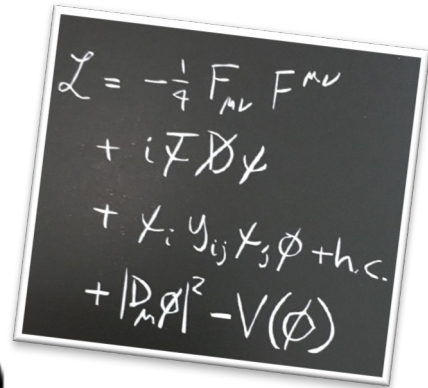

Handwritten Lagrangian on a chalkboard:

$$\mathcal{L} = -\frac{1}{4} F_{\mu\nu} F^{\mu\nu} + i\bar{\psi}\not{D}\psi + \bar{\psi}_i y_{ij} \psi_j \phi + h.c. + |D_\mu \phi|^2 - V(\phi)$$

$$\mathcal{L}_{\text{SMEFT}} = \mathcal{L}_{\text{SM}} + \sum_i^{N_{d6}} \frac{c_i}{\Lambda^2} \mathcal{O}_i^{(6)} + \sum_j^{N_{d8}} \frac{b_j}{\Lambda^4} \mathcal{O}_j^{(8)} + \dots,$$

- $\mathcal{O}_i^{(n)}$ affect rates and kinematics
- STXS measurements and Higgs BR reparametrized in terms of dimension-six Wilson coefficients c_i in Warsaw basis
 - ✓ Correction for modified acceptance in $H \rightarrow 4l$ and $H \rightarrow l\nu l\nu$
 - ✓ U(3)5 flavor symmetry assumed, linearized in Wilson coefficients contribution (linear contribution $\propto \Lambda^{-2}$, expected to be leading)

Can Higgs properties constrain BSM phenomena today?

Wilson coefficient	Operator definition	Example diagram			
c_{HG}	$\Phi^\dagger \Phi G_{\mu\nu}^a G^{a\mu\nu}$		c_{Hl3}	$(i\Phi^\dagger \overleftrightarrow{D}_\mu^I \Phi)(\bar{\ell}\sigma^I \gamma^\mu \ell)$	
c_{HB}	$\Phi^\dagger \Phi B_{\mu\nu} B^{\mu\nu}$		c_{Hu}	$(i\Phi^\dagger \overleftrightarrow{D}_\mu^I \Phi)(\bar{u}\gamma^\mu u)$	
c_{HW}	$\Phi^\dagger \Phi W_{\mu\nu}^I W^{I\mu\nu}$		c_{Hd}	$(i\Phi^\dagger \overleftrightarrow{D}_\mu^I \Phi)(\bar{d}\gamma^\mu d)$	
c_{HWB}	$\Phi^\dagger \Phi W_{\mu\nu}^I B^{I\mu\nu}$		c_{He}	$(i\Phi^\dagger \overleftrightarrow{D}_\mu \Phi)(\bar{e}\gamma^\mu e)$	
c_{Hq1}	$(i\Phi^\dagger \overleftrightarrow{D}_\mu \Phi)(\bar{q}\gamma^\mu q)$		$ c_{uG} $	$(\bar{q}\sigma^{\mu\nu} T^a \Phi u) G_{\mu\nu}^a$	
c_{Hl1}	$(i\Phi^\dagger \overleftrightarrow{D}_\mu \Phi)(\bar{\ell}\gamma^\mu \ell)$		$ c_{eH} $	$(\Phi^\dagger \Phi)(\bar{\ell}e\Phi)$	
c_{Hq3}	$(i\Phi^\dagger \overleftrightarrow{D}_\mu^I \Phi)(\bar{q}\sigma^I \gamma^\mu q)$		$ c_{dH} $	$(\Phi^\dagger \Phi)(\bar{q}d\Phi)$	

EFT interpretation of Higgs couplings: c_i impact

Measurement uncertainty in STXS bin / decay channel

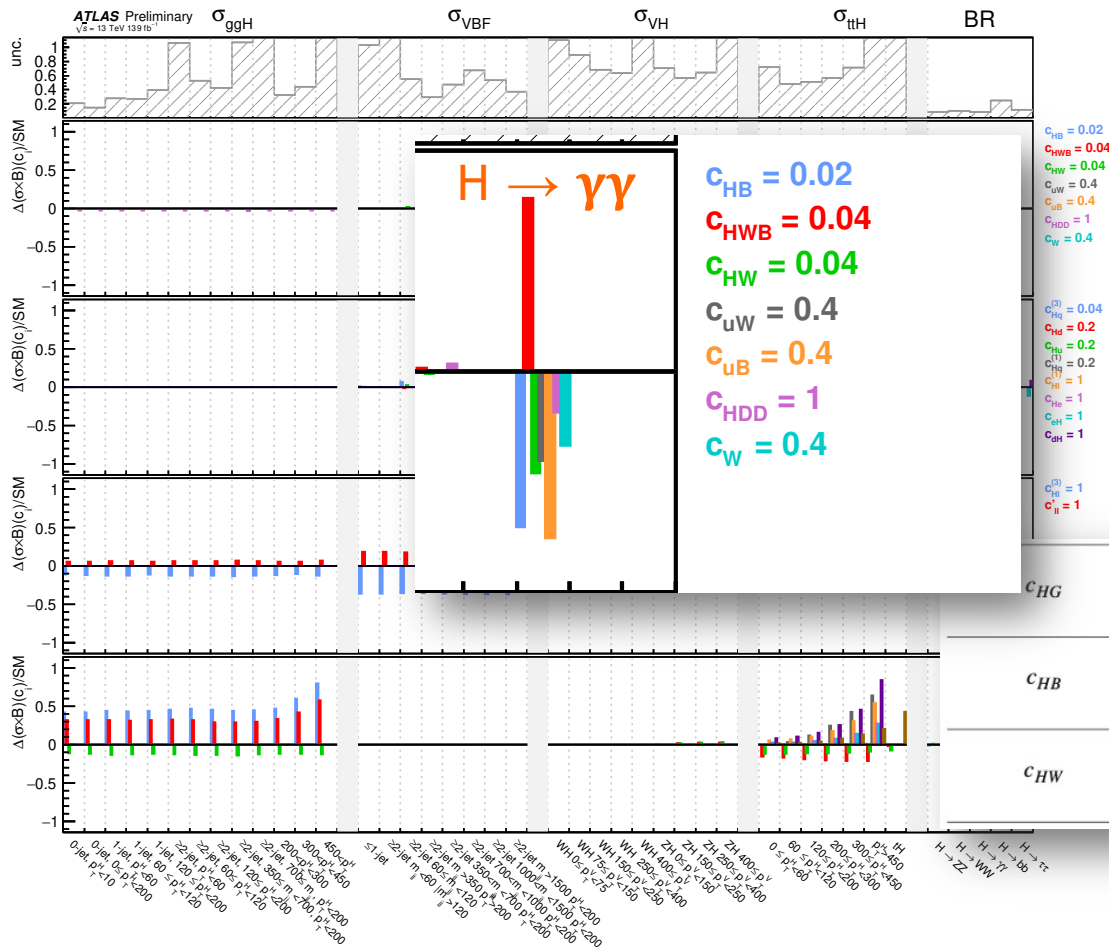

Relative effect of relevant operators

O(I) effects for small values of c_{HB} , c_{HW} , c_{HWB} (tree level $H \rightarrow \gamma\gamma$)

EFT interpretation of Higgs couplings: c_i impact

Measurement uncertainty in STXS bin / decay channel

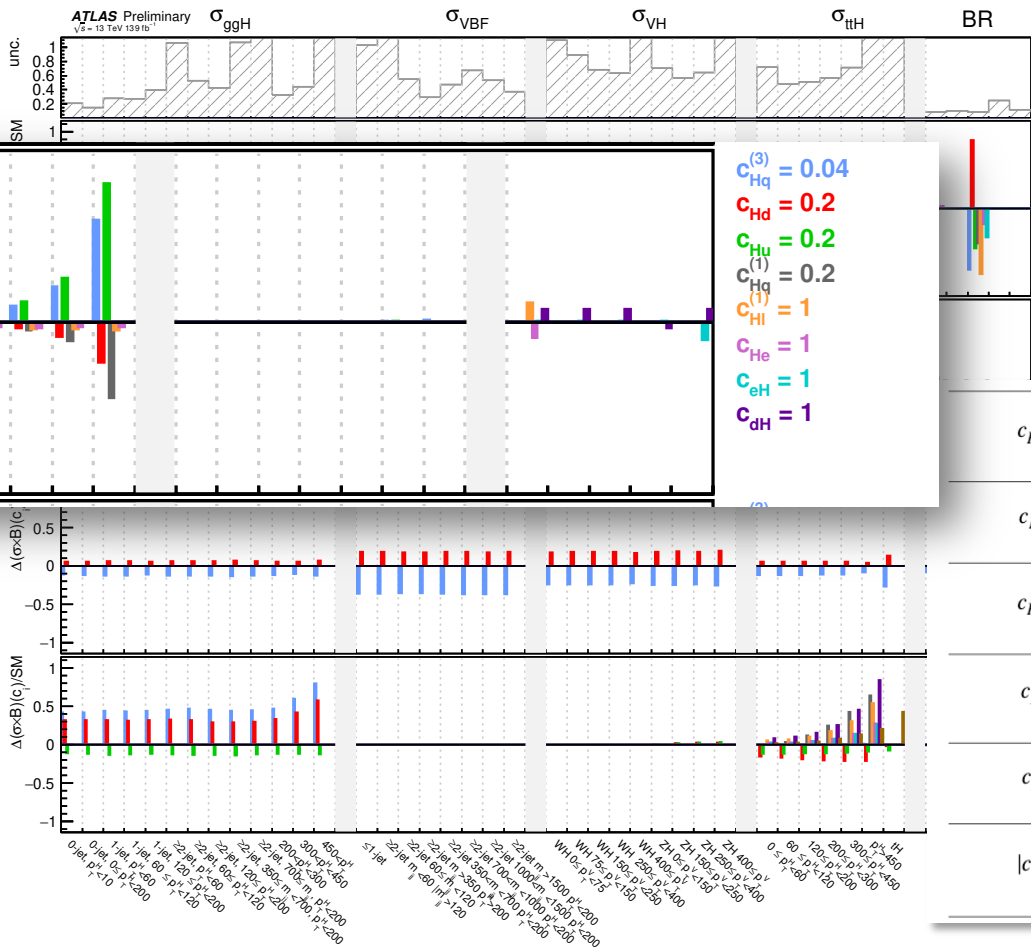

Strong energy growth of effect of $c^{(3)}_{Hg}, c^{(1)}_{Hg}, c_{Hu}, c_{Hd}$

c_{Hq1}	$(i\Phi^\dagger \vec{D}_\mu \Phi)(\bar{q}\gamma^\mu q)$	
c_{Hl1}	$(i\Phi^\dagger \vec{D}_\mu \Phi)(\bar{\ell}\gamma^\mu \ell)$	
c_{Hq3}	$(i\Phi^\dagger \vec{D}_\mu^I \Phi)(\bar{q}\sigma^I \gamma^\mu q)$	
c_{Hd}	$(i\Phi^\dagger \vec{D}_\mu^I \Phi)(\bar{d}\gamma^\mu d)$	
c_{He}	$(i\Phi^\dagger \vec{D}_\mu \Phi)(\bar{e}\gamma^\mu e)$	
$ c_{uG} $	$(\bar{q}\sigma^{\mu\nu} T^a \Phi u) G_{\mu\nu}^a$	

EFT interpretation of Higgs couplings

- Simultaneously constraining all coefficients impossible
- Fit performed in *sensitive directions*
 - ✓ linear combinations informed by principal component analysis
- Examples
 - ✓ $c^{[1]}_{HG,uG,uH}$: linear comb. with strong impact on $gg \rightarrow H$
 - ✓ $c^{[1]}_{HW,HB,HWB,HDD,uW,uB,W}$: strong impact on $H \rightarrow \gamma\gamma$
 - ✓ $c^{(3)}_{Hq}$: unique impact on VH

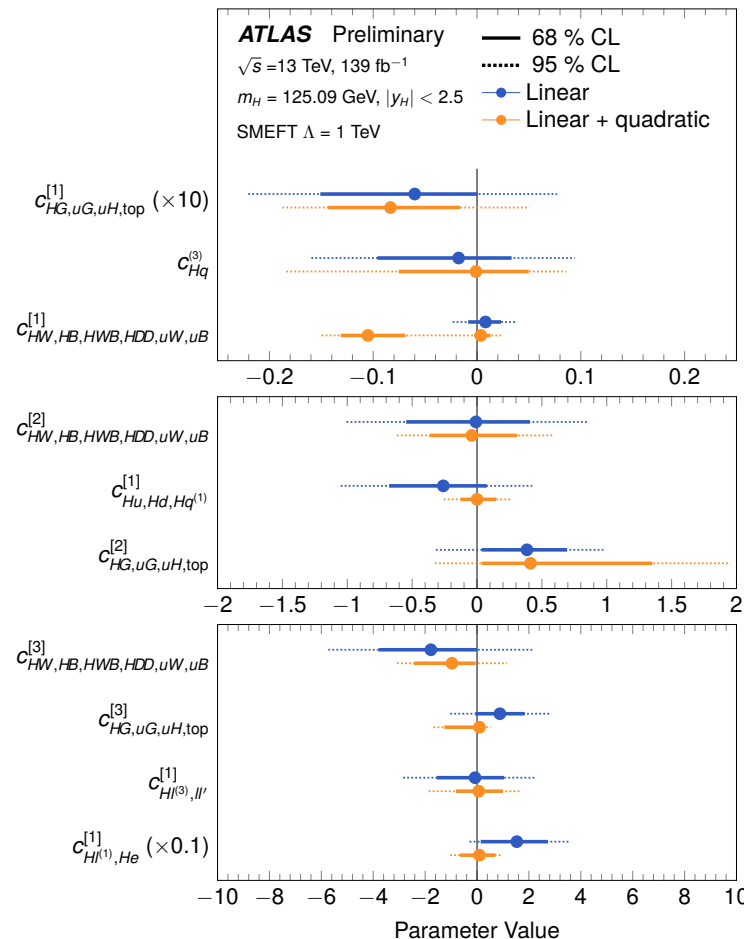

ATLAS Preliminary $\sqrt{s}=13$ TeV, 139 fb⁻¹

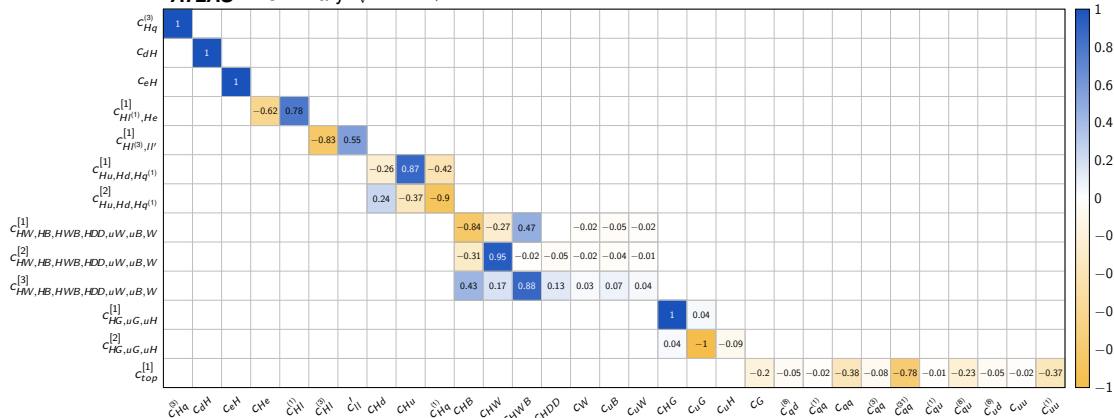

13.

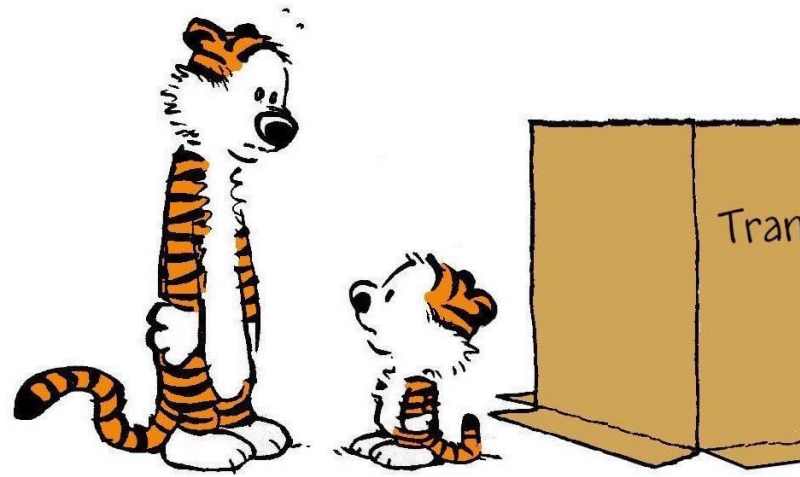

The SM missing piece

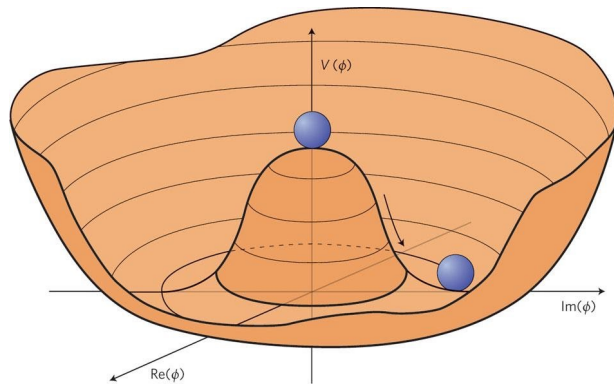

$$V(\Phi) = -\mu^2 \Phi^\dagger \Phi + \lambda (\Phi^\dagger \Phi)^2$$

$$V(\Phi) = V_0 + \frac{1}{2} m_H^2 H^2 + \lambda \nu H^3 + \frac{1}{4} \lambda H^4$$

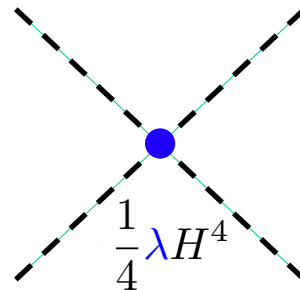
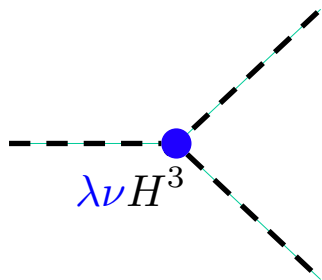

Can we access the Higgs self-coupling at the LHC?

- Main avenues toward self-coupling measurement at LHC
 - ✓ Direct: HH production
 - ✓ Indirect: constraints from single Higgs measurements
- HH production
 - ✓ Very low cross-section ($\sim 1000\times$ smaller than single Higgs!)
 - ✓ Destructive interference between $gg \rightarrow HH$ processes

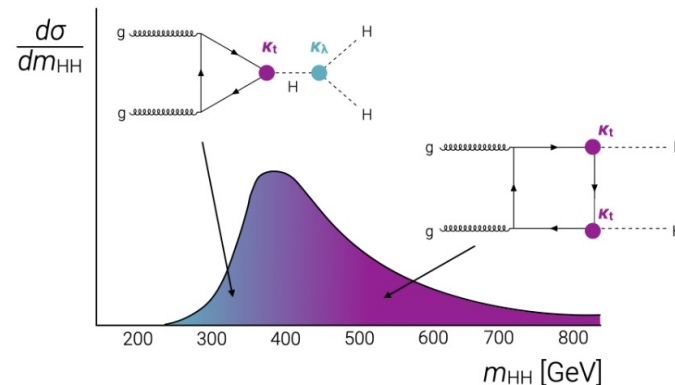

gluon-fusion
 $\sigma_{ggF}(pp \rightarrow HH) = 31.05 \text{ fb}$

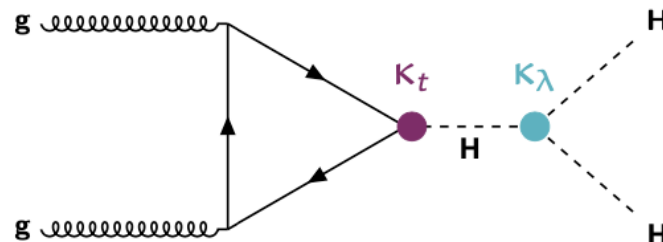
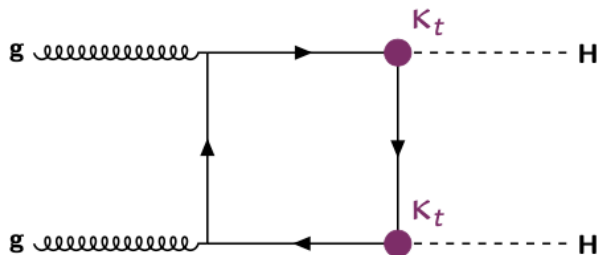

VBF
 $\sigma_{VBF}(pp \rightarrow HH) = 1.726 \text{ fb}$

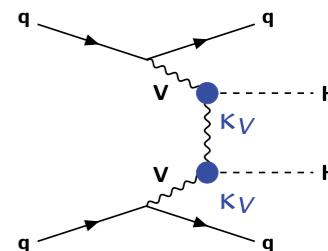
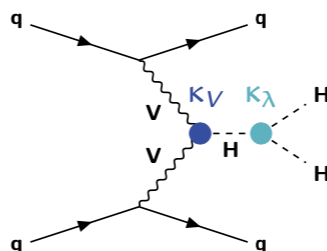
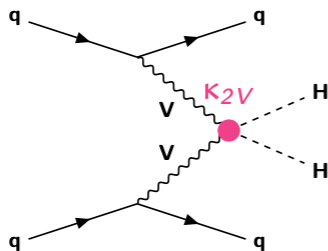

How to measure di-Higgs production?

	bb	WW	$\tau\tau$	ZZ	$\Upsilon\Upsilon$
bb	34%				
WW	25%	4.6%			
$\tau\tau$	7.3%	2.7%	0.39%		
ZZ	3.1%	1.1%	0.33%	0.069%	
$\Upsilon\Upsilon$	0.26%	0.10%	0.028%	0.012%	0.0005%

Closing in on di-Higgs production!

Phys. Lett. B 843 (2024) 137745

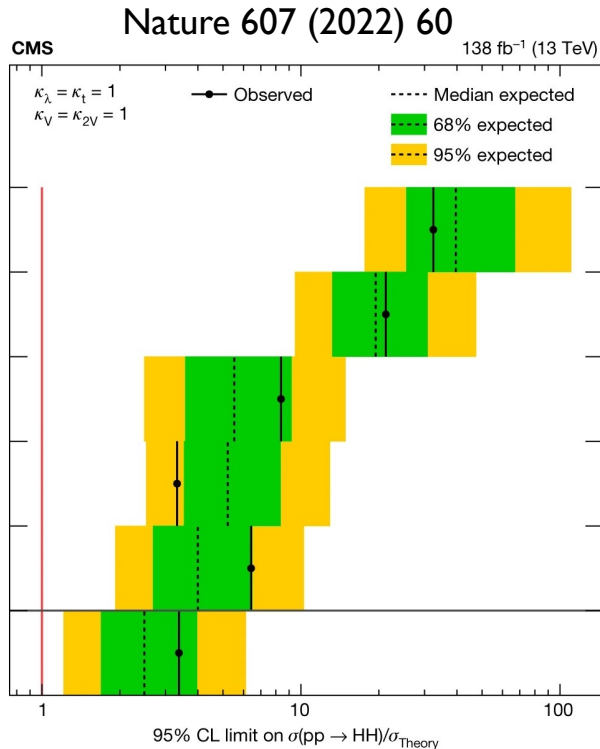
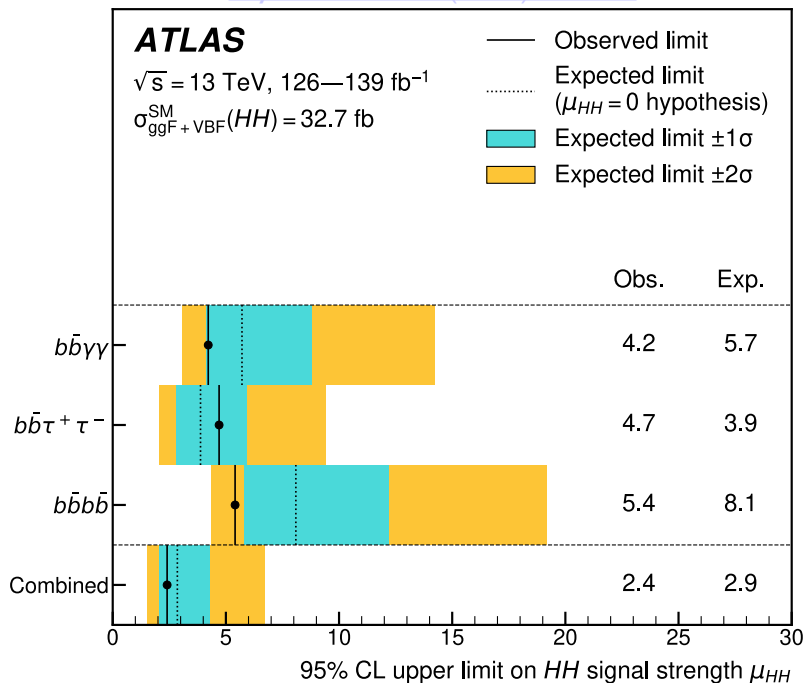

Closing in on di-Higgs production!

arXiv:2211.01216

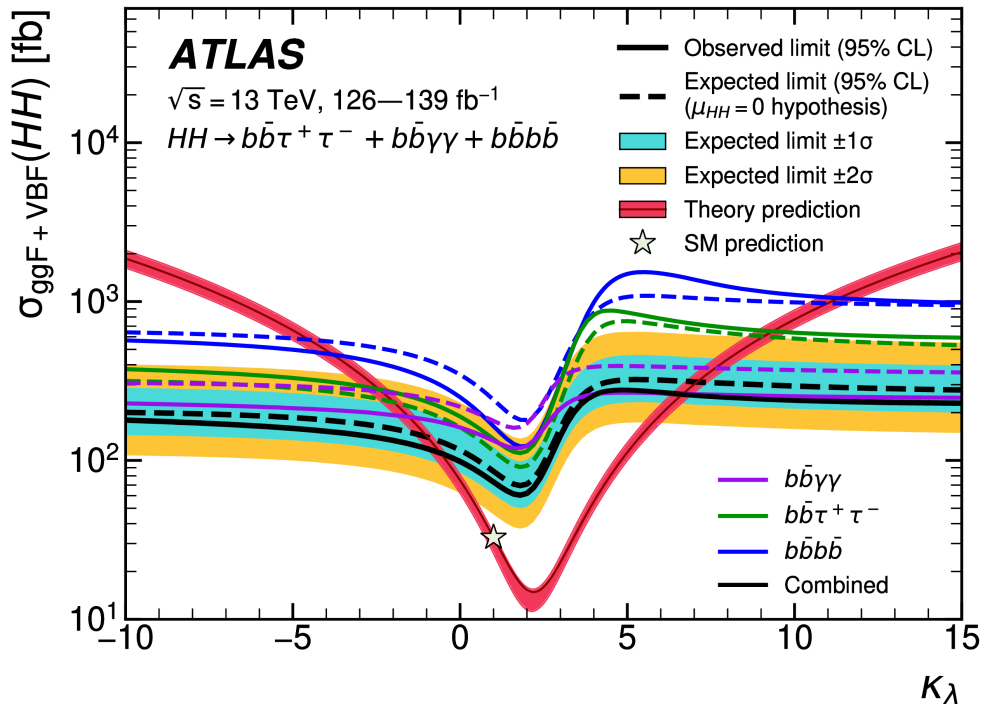

$-0.4 < \kappa_\lambda < 6.3 @ 95\% \text{ CL}$

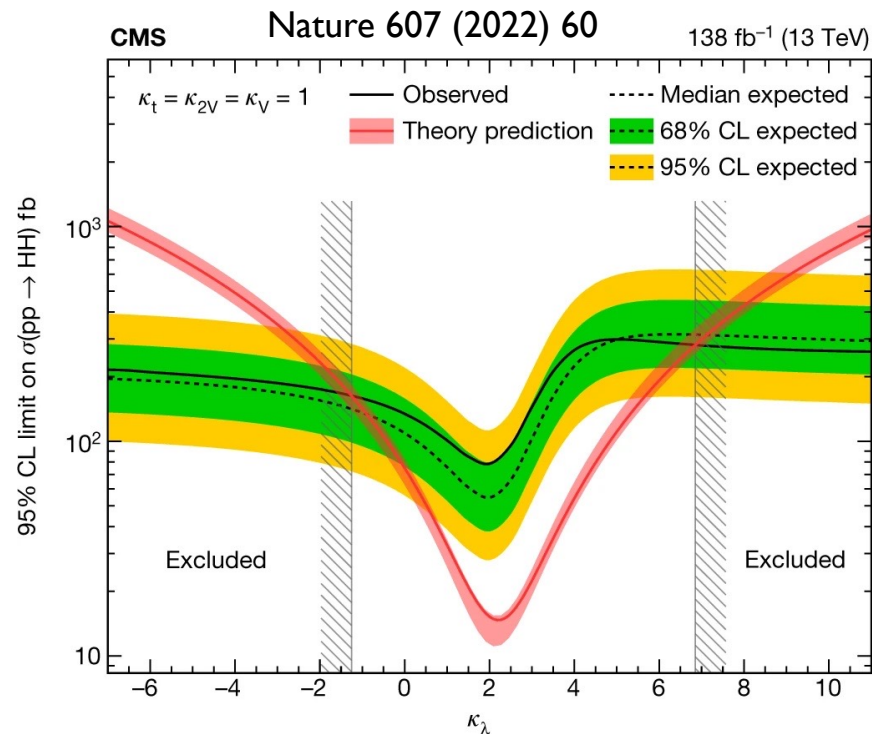

$-1.24 < \kappa_\lambda < 6.49 @ 95\% \text{ CL}$

- Limits on κ_λ are improving dramatically, and there is more to be exploited...

di-Higgs at LHC: the Run 2 legacy

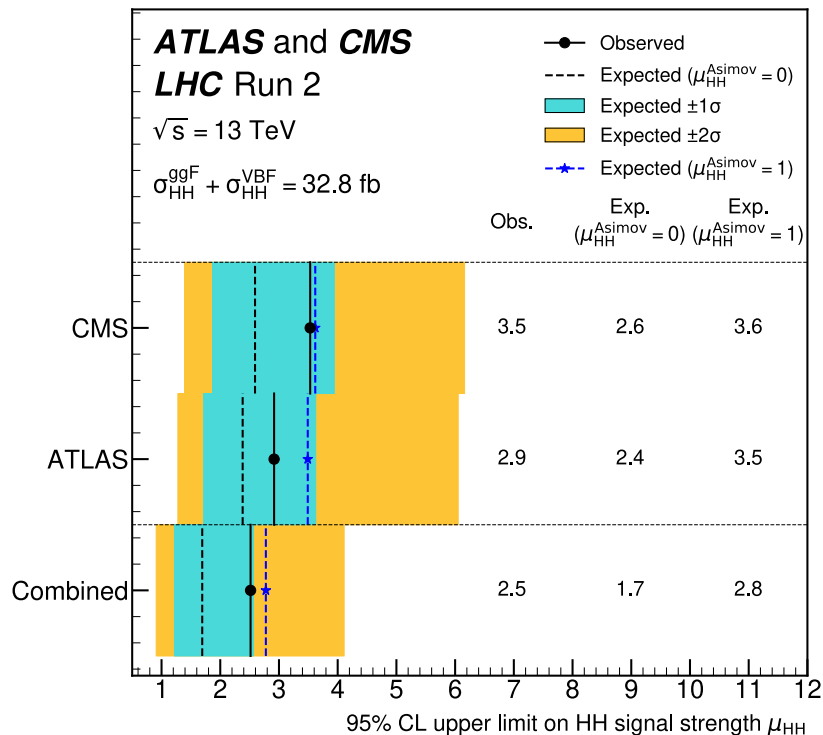

ATLAS +CMS
 $\mu_{\text{HH}} < 2.5 @ 95\% \text{ CL}$

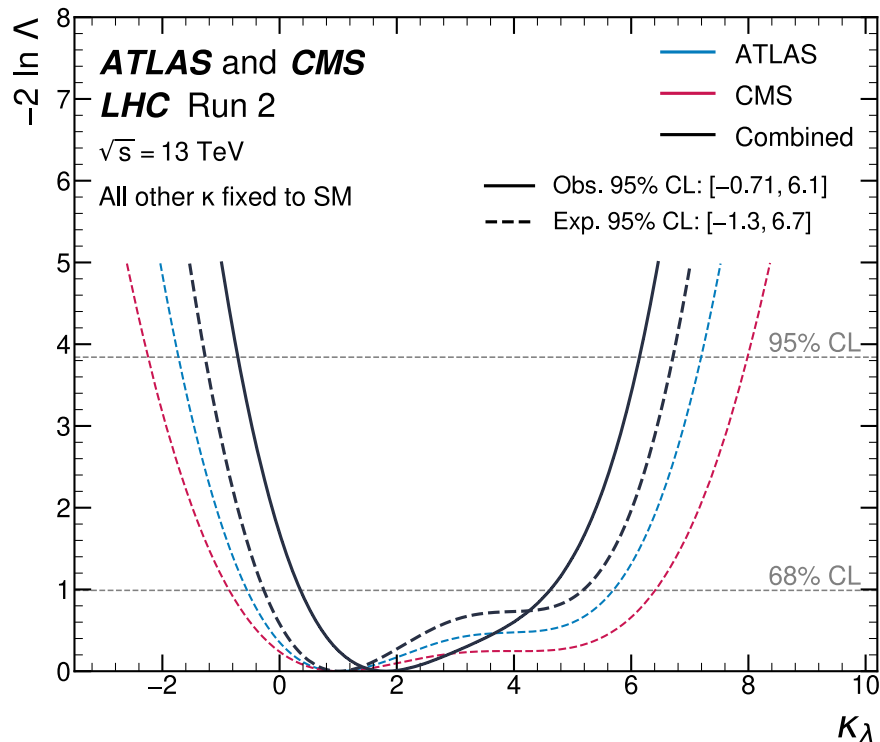

ATLAS +CMS
 $-0.71 < \kappa_\lambda < 6.1 @ 95\% \text{ CL}$

di-Higgs at LHC: Run 2 already chiming in...

YY	0.26%
----	-------

[Phys. Lett. B 876 \(2026\) 140280](#)

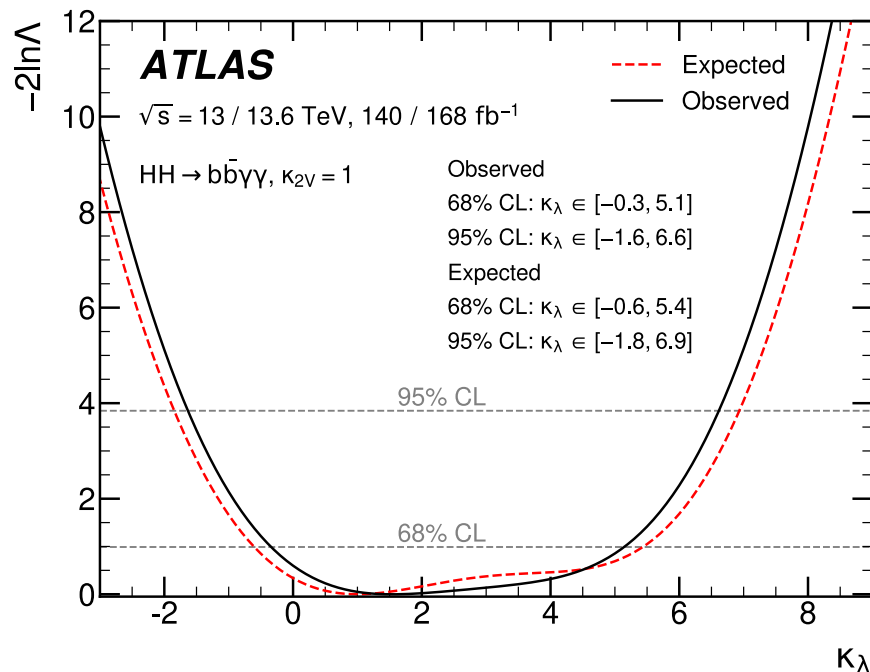
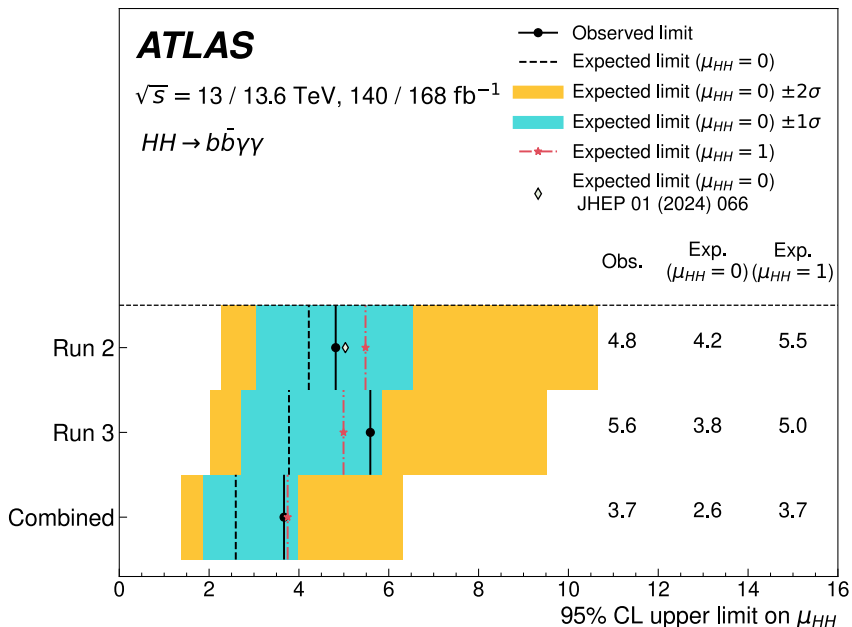

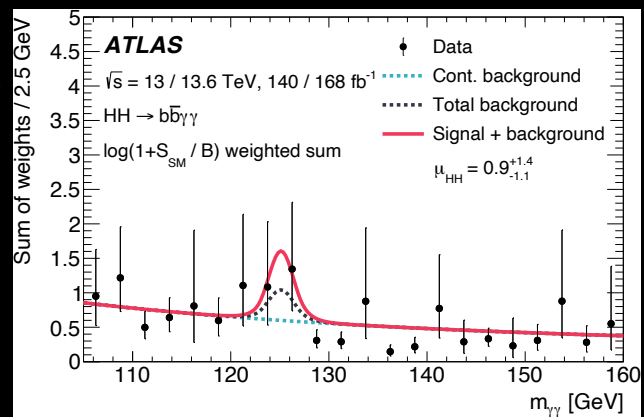
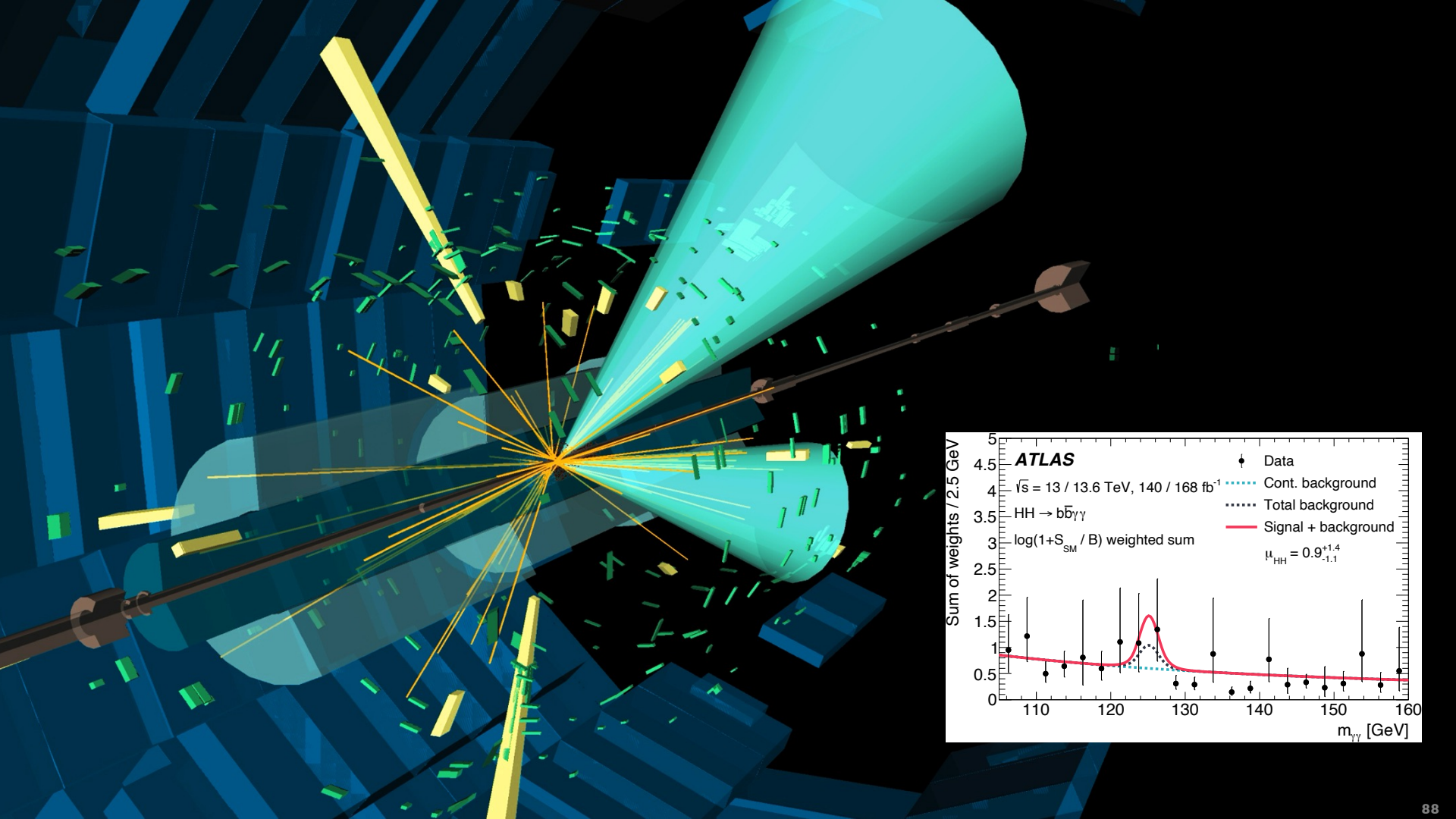

When will we find the missing piece of the SM?

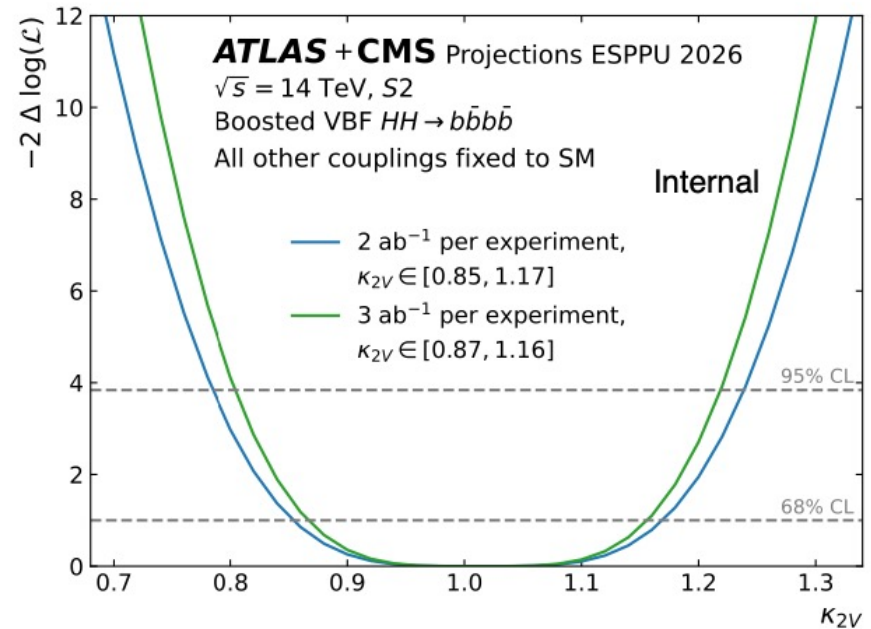
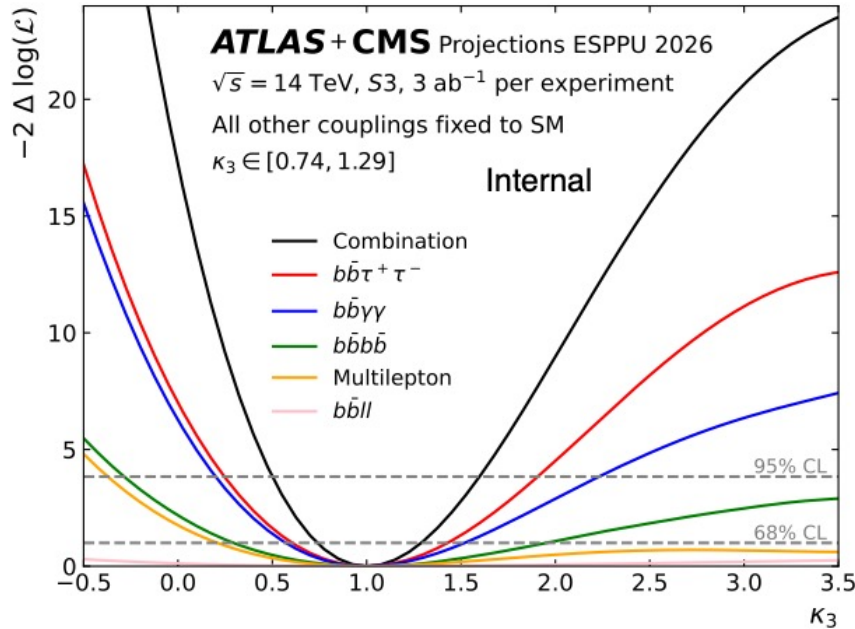

Figure 2: *Left:* ATLAS+CMS κ_3 likelihood scans for single decay channels and the combination for 3 ab^{-1} for the $S3$ scenario. *Right:* The ATLAS+CMS projections for κ_{2V} in the $S2$ scenario.

- $HH \rightarrow b\bar{b}\gamma\gamma$ = both ATLAS and CMS,
- $HH \rightarrow b\bar{b}\tau\tau, \rightarrow b\bar{b}ll, \rightarrow \text{multileptons}$ + ATLAS $\times 2$
- $HH \rightarrow b\bar{b}b\bar{b}$ resolved and boosted = CMS $\times 2$
- VBF boosted $HH \rightarrow b\bar{b}b\bar{b}$ = ATLAS $\times 2$

Projection of non-resonant ATLAS+CMS HH combination

	2 ab ⁻¹ (S2)		3 ab ⁻¹ (S2)		3 ab ⁻¹ (S3)	
	ATLAS	CMS	ATLAS	CMS	ATLAS	CMS
<i>HH</i> statistical significance						
$b\bar{b}\tau^+\tau^-$	3.0	1.9	3.5	2.4	3.8	2.7
$b\bar{b}\gamma\gamma$	2.1	2.0	2.4	2.4	2.6	2.6
$b\bar{b}b\bar{b}$ resolved	0.9	1.0	1.0	1.2	1.0	1.3
$b\bar{b}b\bar{b}$ boosted	–	1.8	–	2.2	–	2.2
Multilepton	0.8	–	1.0	–	1.0	–
$b\bar{b}\ell^+\ell^-$	0.4	–	0.5	–	0.5	–
Combination	3.7	3.5	4.3	4.2	4.5	4.5
ATLAS+CMS	6.0		7.2		7.6	
κ_3 68% confidence interval						
$b\bar{b}\tau^+\tau^-$	[0.3, 1.8]	[0.1, 3.0]	[0.4, 1.7]	[0.2, 2.2]	[0.5, 1.6]	[0.3, 2.0]
$b\bar{b}\gamma\gamma$	[0.3, 2.0]	[0.2, 2.3]	[0.4, 1.8]	[0.3, 2.0]	[0.5, 1.7]	[0.4, 1.9]
$b\bar{b}b\bar{b}$ resolved	[-0.7, 6.3]	[-0.6, 7.6]	[-0.5, 6.1]	[-0.3, 7.3]	[-0.5, 6.1]	[-0.3, 7.2]
$b\bar{b}b\bar{b}$ boosted	–	[-0.6, 8.5]	–	[-0.4, 8.2]	–	[-0.4, 8.2]
Multilepton	[-0.2, 4.9]	–	[-0.1, 4.7]	–	[-0.1, 4.7]	–
$b\bar{b}\ell^+\ell^-$	[-2.4, 9.3]	–	[-2.2, 9.2]	–	[-2.1, 9.1]	–
Combination	[0.6, 1.5]	[0.4, 1.7]	[0.6, 1.5]	[0.5, 1.6]	[0.6, 1.4]	[0.6, 1.5]
ATLAS+CMS uncertainty	-32% / +37%		-27% / +31%		-26% / +29%	

- ~4 sigma in EPPU 2020
- Now close to single experiment observation !

Table 2: ATLAS and CMS expected statistical significance for *HH* production and the corresponding 68% confidence interval on κ_3 at 3 ab⁻¹, derived assuming $\kappa_3^{\text{true}} = 1$.

Bonus: constraining the shape of the Higgs potential

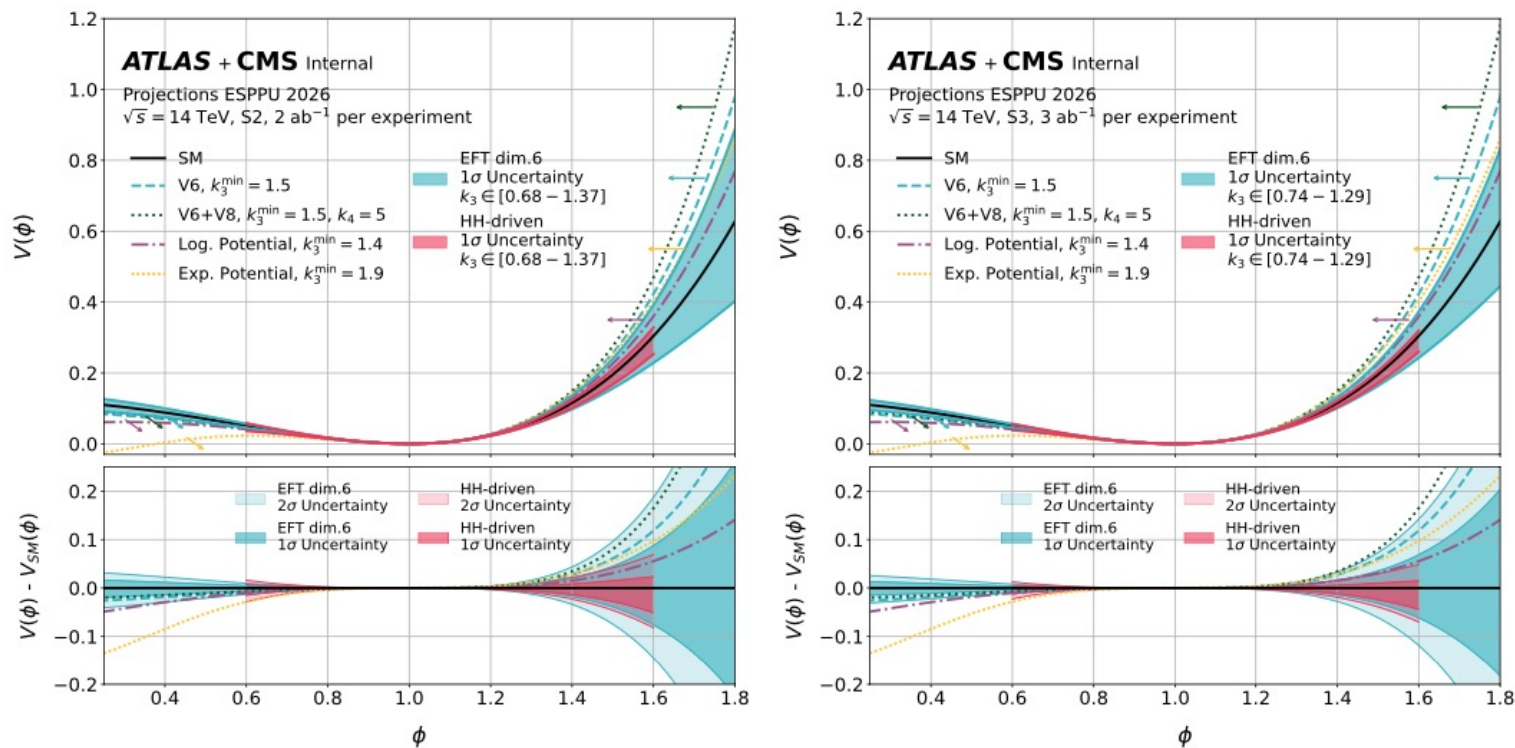
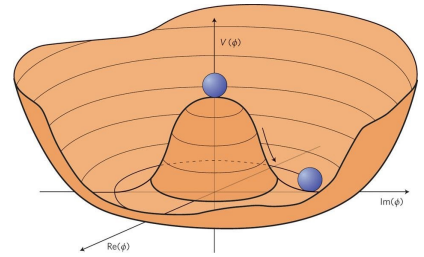

Figure 5: BEH potentials in various models which predict first-order phase transition [67]. The models are compared with the SM BEH potential. Two approaches (EFT dim-6 and HH-driven) are used to show the expected uncertainties on the Higgs self-coupling achieved by combining ATLAS and CMS at 2 ab^{-1} in the S2 scenario (left) and at 3 ab^{-1} in the S3 scenario (right).



14.



The road ahead

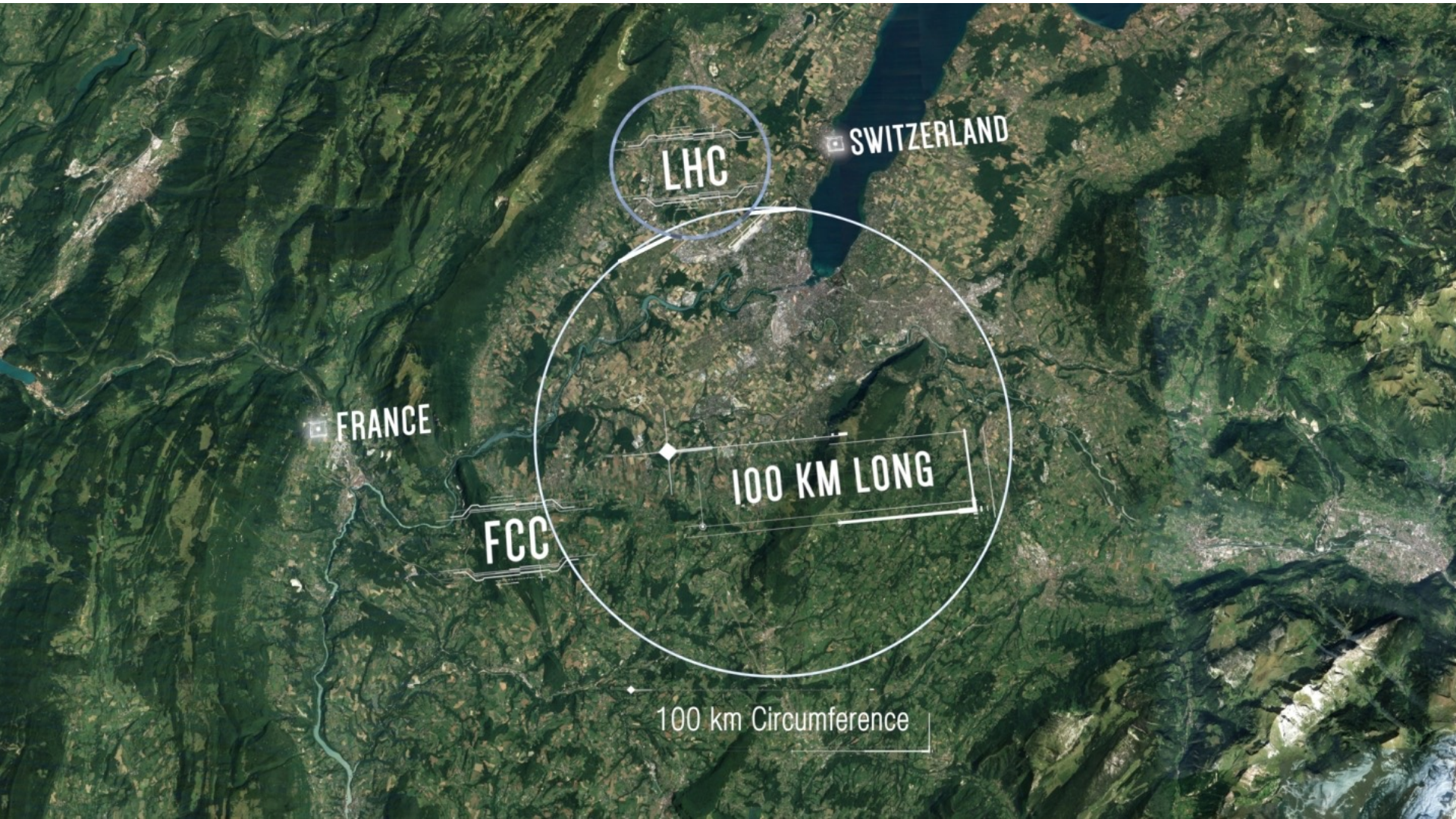

LHC

SWITZERLAND

FRANCE

FCC

100 KM LONG

100 km Circumference

FCC Feasibility studies

**Future Circular Collider
Feasibility Study Report**

arXiv:2505.00272v1 [hep-ex] 25 Apr 2025

**Volume 1
Physics, Experiments, Detectors**

May 2, 2025

Submitted to the European Physics Journal ST, a joint publication of EDP Sciences, Springer Science+Business Media, and the Società Italiana di Fisica.

[arXiv:2505.00272](https://arxiv.org/abs/2505.00272)

**Future Circular Collider
Feasibility Study Report**

**Volume 2
Accelerators, Technical Infrastructure
and Safety**

March 31, 2025

Submitted to the European Physics Journal ST, a joint publication of EDP Sciences, Springer Science+Business Media, and the Società Italiana di Fisica.

[arXiv:2505.00274](https://arxiv.org/abs/2505.00274)

**Future Circular Collider
Feasibility Study Report**

arXiv:2505.00273v1 [physics.acc-ph] 25 Apr 2025

**Volume 3
Civil Engineering, Implementation
and Sustainability**

March 31, 2025

Submitted to the European Physics Journal ST, a joint publication of EDP Sciences, Springer Science+Business Media, and the Società Italiana di Fisica.

[arXiv:2505.00273](https://arxiv.org/abs/2505.00273)

Higgs at FC-ee

$L = 5 \text{ ab}^{-1}$
 $ZH = 10^6$
 $VBF = 2 \times 10^4$

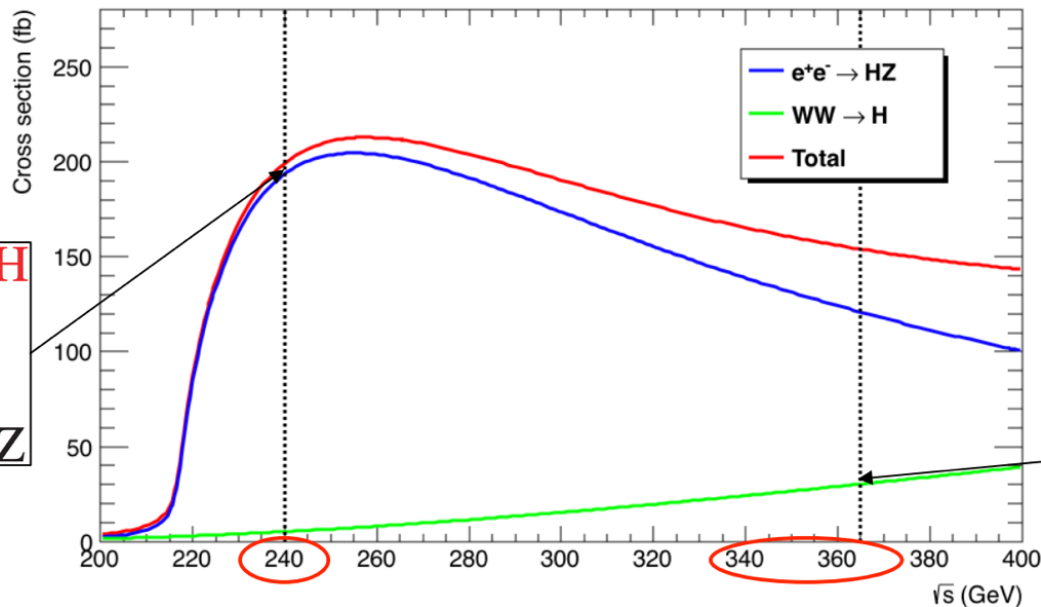
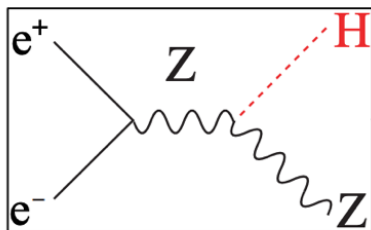

$L = 1.5 \text{ ab}^{-1}$
 $ZH = 2.5 \times 10^5$
 $VBF = 5 \times 10^4$

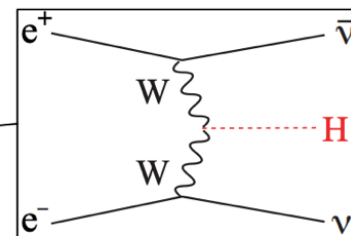

Why? How much will we exceed HL-LHC precision?

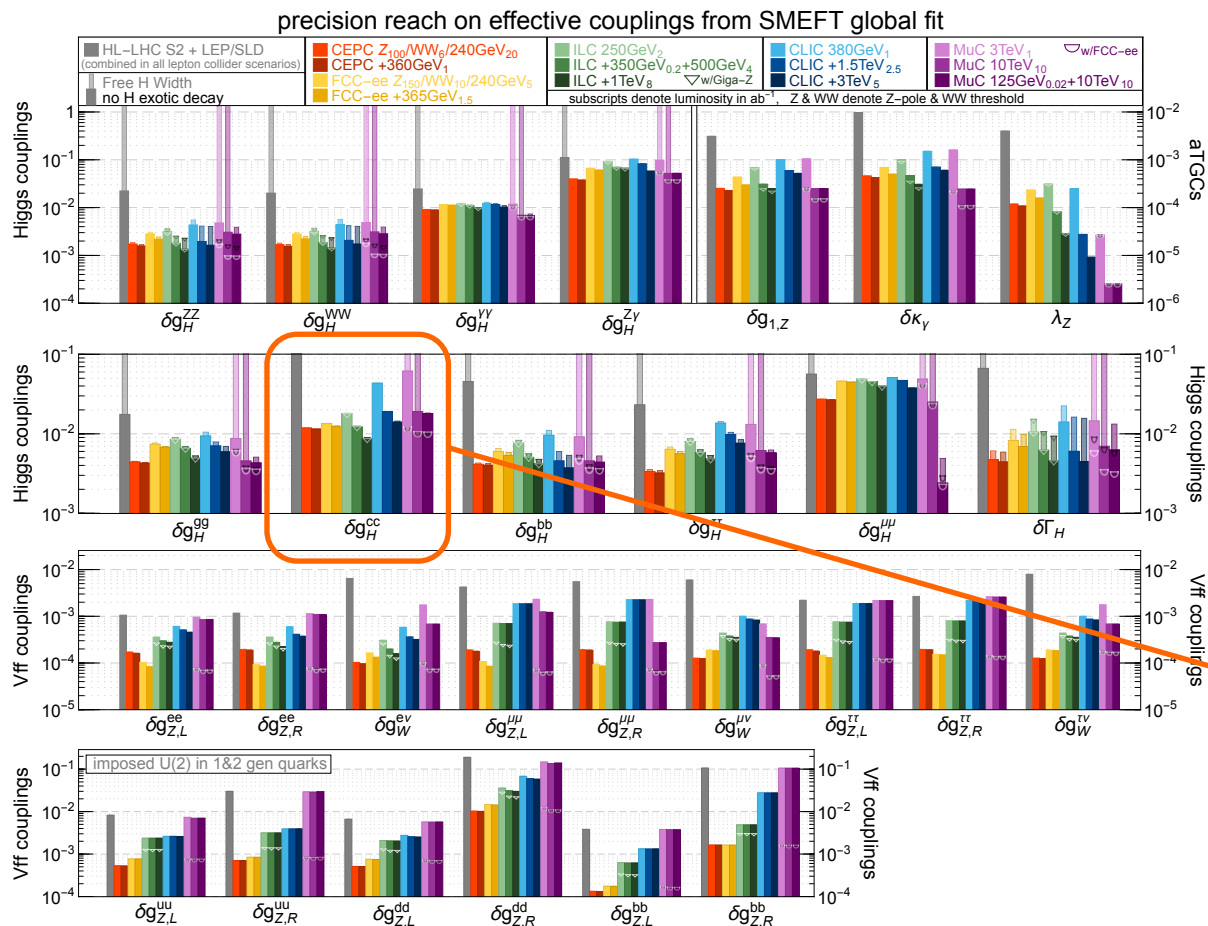

HL-LHC: gray
Future colliders: colors

Caveat: comparison between FC not always fair (luminosity and number of experiments evolved from 2022), CEPC projection very aggressive

Precision on EW/Higgs/top properties will allow indirect BSM detection (crucial is BSM is at very high mass / energy, difficult to directly reach)

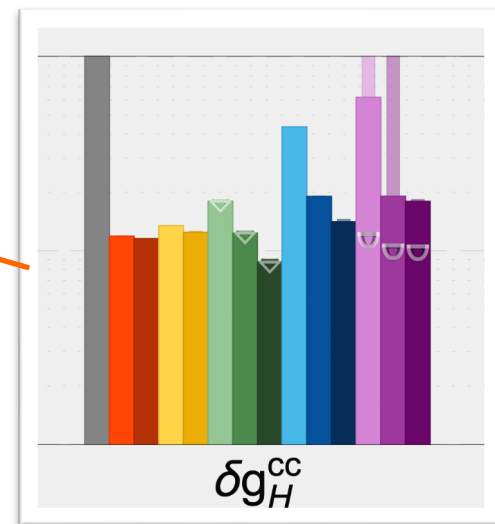

FCC project timeline

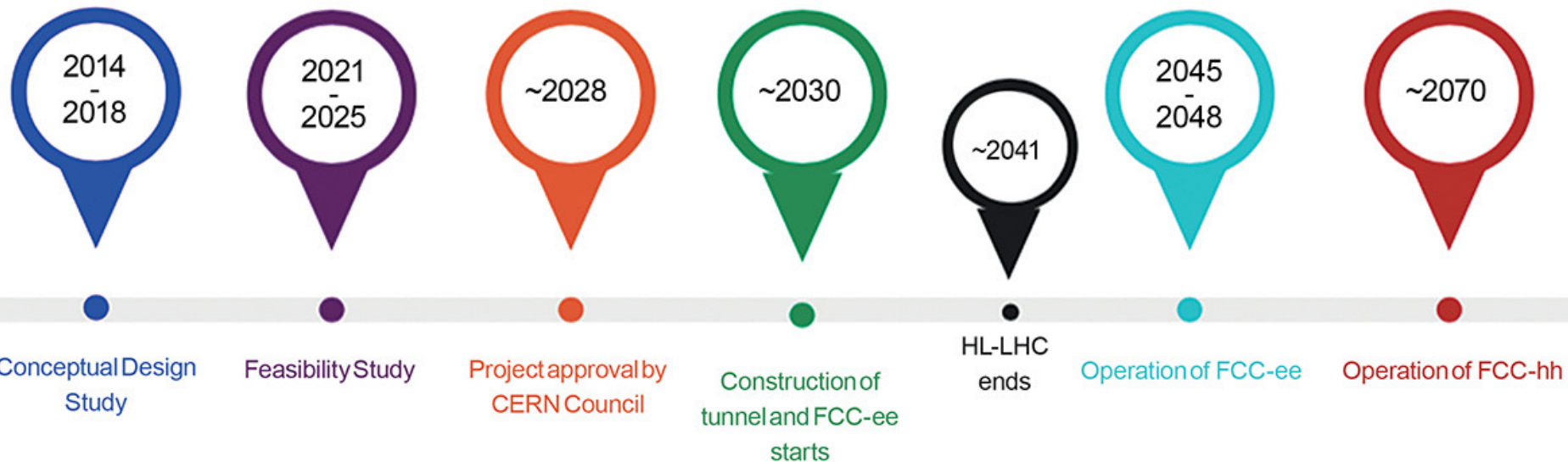





Peter Higgs following the Higgs
announcement seminar on July 4 2012

$e^{i\pi}$.

More material

First bounds

- Effect on Cosmic Microwave background ($0.1 \text{ eV} < m_H < 100 \text{ eV}$)
 - ✓ (Sato and Sato, 1975)
- Emission from stars: $m_H > 0.7 m_e$
 - ✓ (Sato and Sato, 1975)
- Neutron-electron scattering: $m_H > 0.7 \text{ MeV}$
 - ✓ (Rafelski, Muller, Soff and Greiner; Watson and Sundaresan, 1974)
- Neutron-electron scattering: $m_H > 0.7 \text{ MeV}$
 - ✓ (Adler, Dashen and Treiman; 1974)
- Neutron-nucleus scattering: $m_H > 13 \text{ MeV}$
 - ✓ (Barbieri and Ericson, 1975)
- Nuclear $^{16}\text{O}(6.05 \text{ MeV})$ to ground state ($0^+ - 0^+$) transitions (can occur through Higgs emission): $m_H > 18 \text{ MeV}$
 - ✓ (Kohler, Watson and Becker, 1974)

Pre-LEP bounds

- SINDRUM Collaboration measured $\pi \rightarrow e\nu H$ (ee)
Yielding a limit on very light Higgs
- CUSB Collaboration $\Upsilon \rightarrow H\gamma$ yielding limit of ~ 5 -
 6 GeV (dependent on high order corrections)
- Jade and CLEO provided bounds on $B \rightarrow \mu\mu+X$
- CERN-Edinburgh-Orsay-Mainz-Pisa-Siegen $K \rightarrow \pi$
 $H(ee)$ below ~ 50 MeV
- Electron beam dump $e \rightarrow eH(ee)$ excluded 1.2
MeV to 52 MeV (theory uncertainties free)

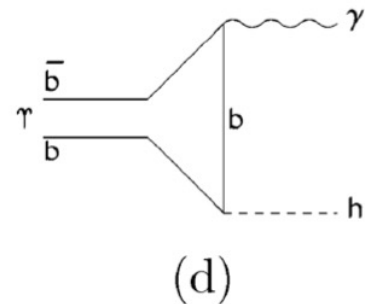
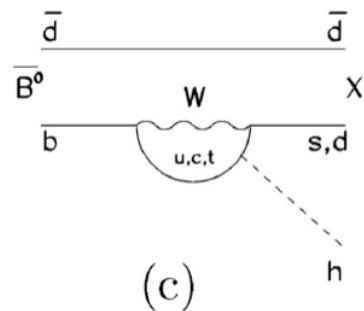
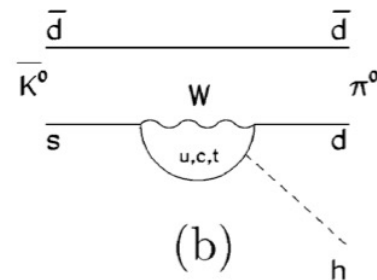
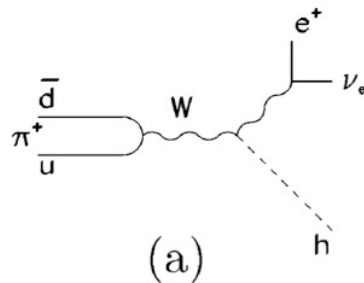

1990: The Higgs Hunter Guide

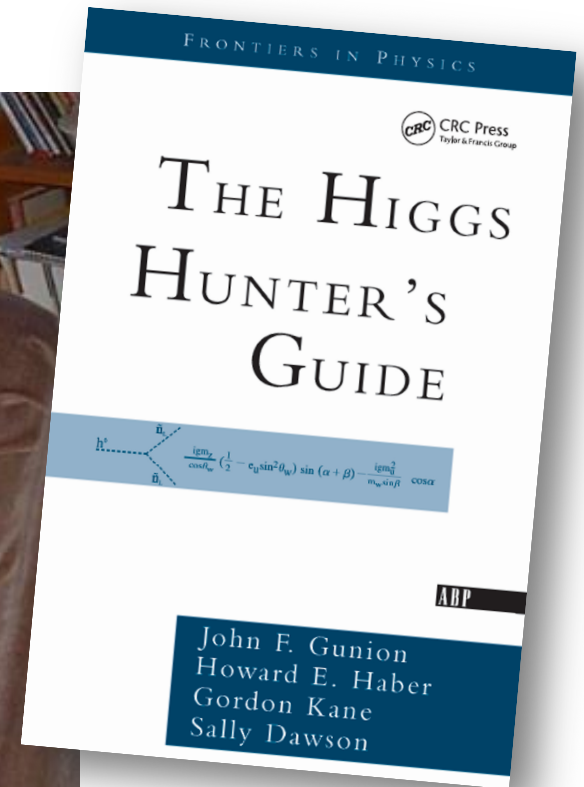

Michael Peskin
(SLAC) peruses the
Higgs Hunter's Guide
published in 1990

SM Higgs sector

$$\begin{aligned}
 \mathcal{L} = & \frac{1}{2} \partial_\mu H \partial^\mu H - \frac{1}{2} \lambda v^2 H^2 - \lambda v H^3 - \frac{\lambda}{4} H^4 \quad \text{massive scalar : the Higgs boson} \\
 & + \frac{1}{2} \left[\frac{g'^2 v^2}{4} B_\mu B^\mu - \frac{gg'v^2}{2} W_\mu^3 B^\mu + \frac{g^2 v^2}{4} \vec{W}_\mu \cdot \vec{W}^\mu \right] \quad \text{massive gauge bosons} \\
 & + \frac{1}{v} \left[\frac{g'^2 v^2}{4} B_\mu B^\mu H - \frac{gg'v^2}{2} W_\mu^3 B^\mu H + \frac{g^2 v^2}{4} \vec{W}_\mu \cdot \vec{W}^\mu H \right] \\
 & + \frac{1}{2v^2} \left[\frac{g'^2 v^2}{4} B_\mu B^\mu H^2 - \frac{gg'v^2}{2} W_\mu^3 B^\mu H^2 + \frac{g^2 v^2}{4} \vec{W}_\mu \cdot \vec{W}^\mu H^2 \right] \quad \left. \vphantom{\frac{1}{v}} \right\} \text{gauge-Higgs interaction}
 \end{aligned}$$

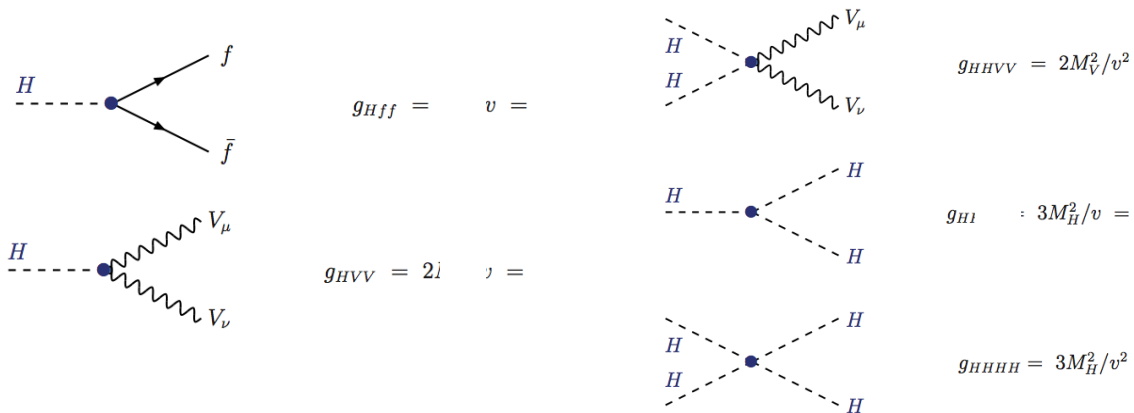

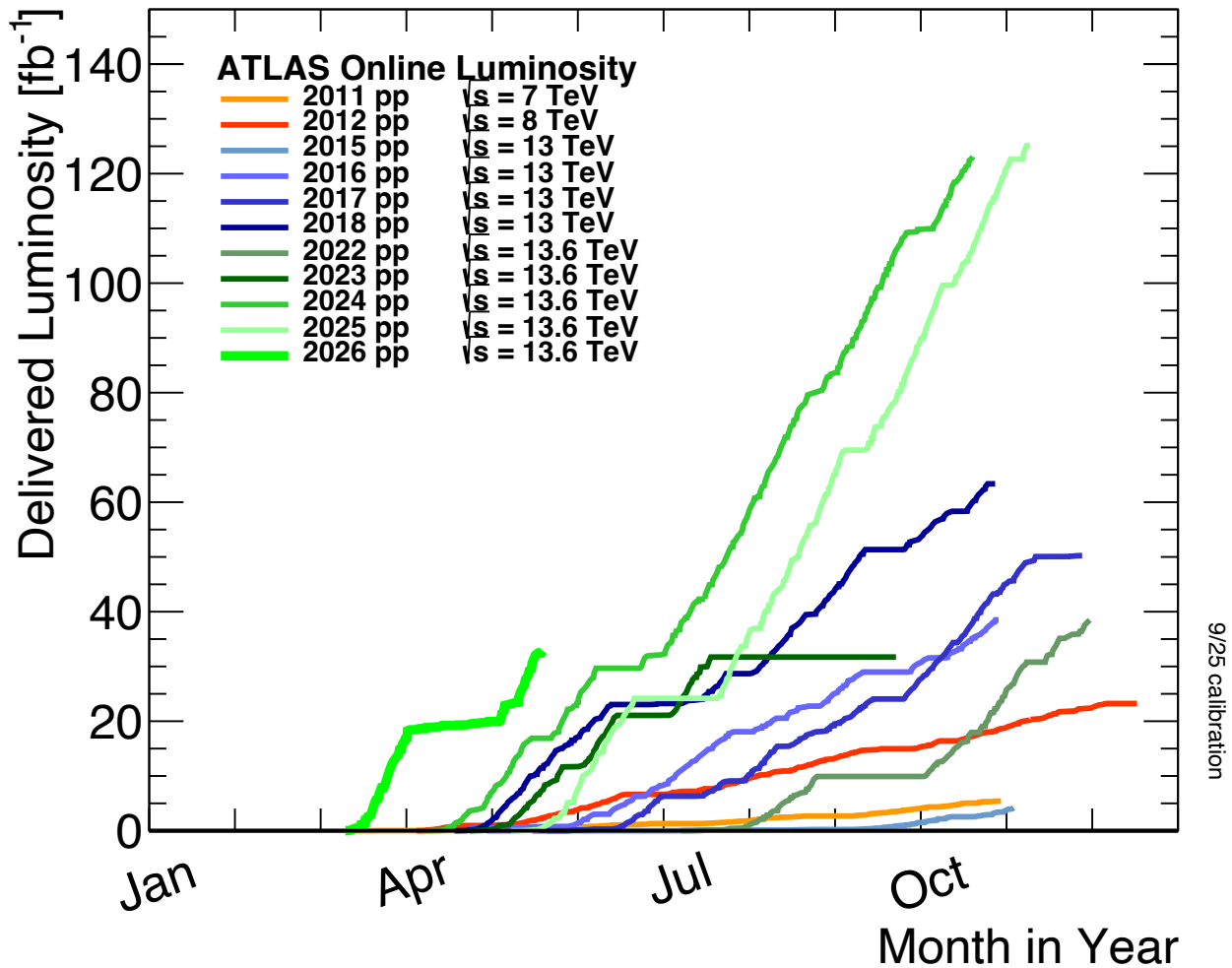

Knowing the Higgs mass values...

... allows to make precision predictions

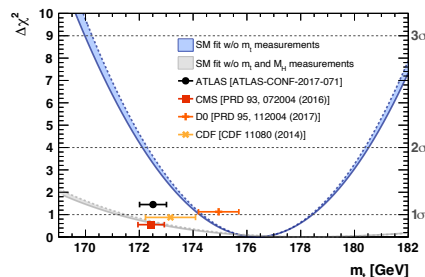
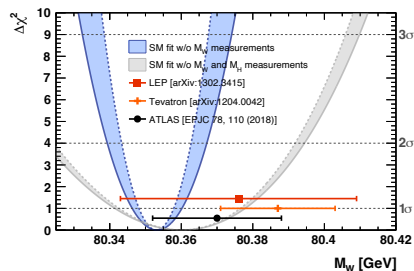
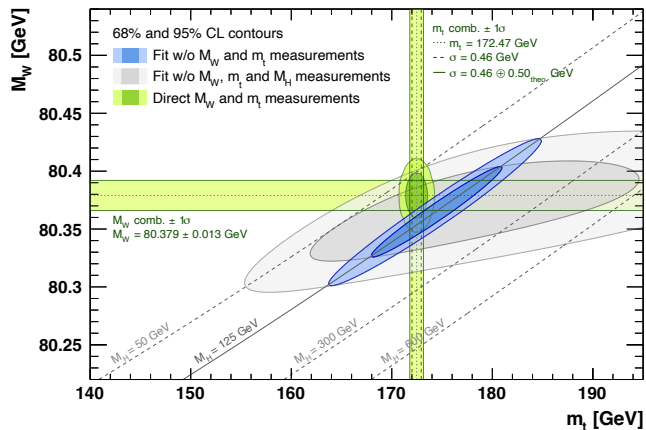

... but current m_H precision has little impact

... questions us on vacuum (meta) stability

$$V(\Phi) = -\mu^2 \Phi^\dagger \Phi + \lambda (\Phi^\dagger \Phi)^2$$

$$m_H = \sqrt{2\lambda} \nu$$

Running of the Higgs self coupling,
assuming SM only at high scale

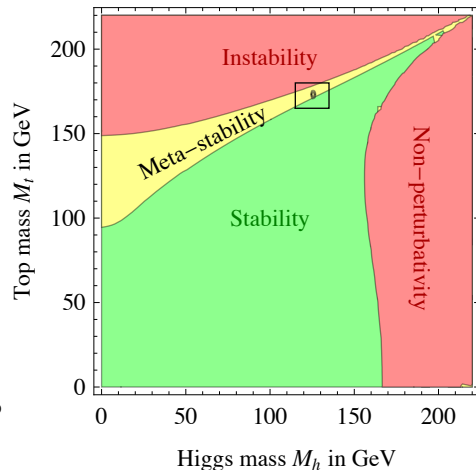
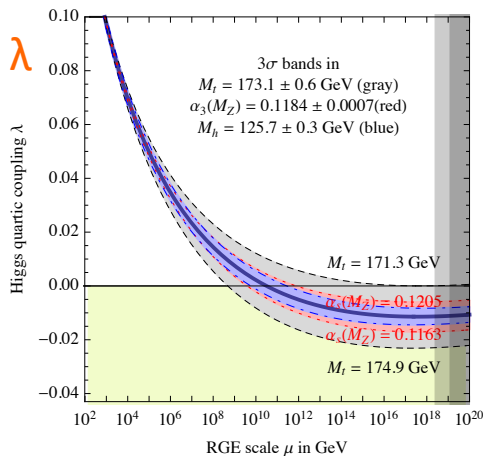

Vanishing quartic coupling at the Planck scale? Potential not bounded?
... but interpretation more sensitive to precision on top quark mass

CP properties of Higgs- τ coupling with $H \rightarrow \tau\tau$

Effective Lagrangian for Yukawa coupling to tau leptons parameterized by **CP-Even** and **CP-odd** components

$$\mathcal{L}_{H\tau\tau} = -\frac{m_\tau}{\nu} \kappa_\tau \left(\cos \phi_\tau \bar{\tau}\tau + \sin \phi_\tau \bar{\tau}i\gamma_5\tau \right) H$$

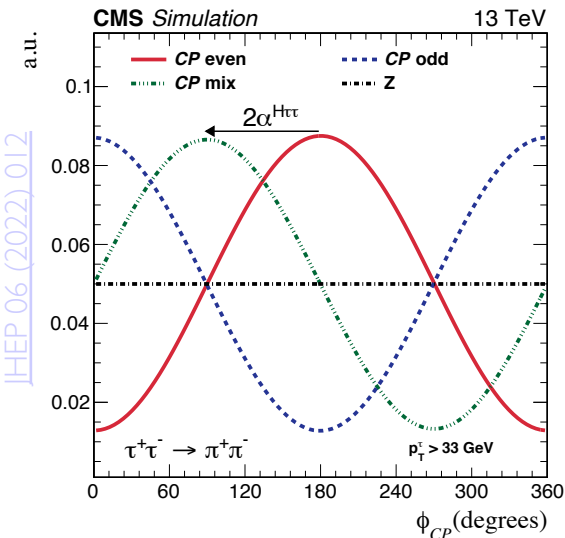
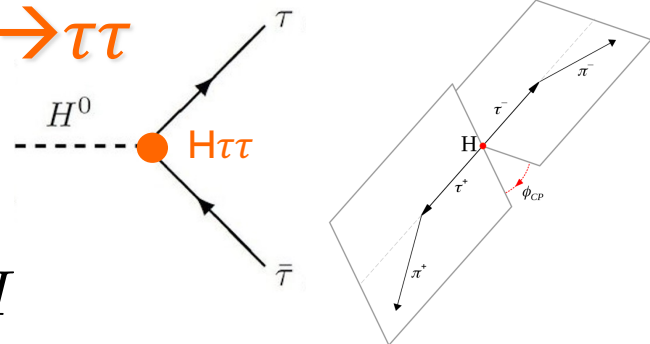

$$\alpha^{H\tau\tau}(\text{CMS}) = \phi_\tau(\text{ATLAS})$$

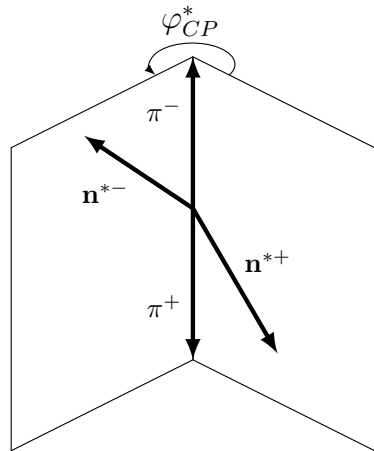

$$H \rightarrow \tau^+\tau^- \rightarrow \pi^+\pi^- + 2\nu$$

$$\phi^* = \arccos(\hat{n}_\perp^{*+} \cdot \hat{n}_\perp^{*-})$$

Uses either the impact parameter direction for single-prong taus (π^\pm) or π^0 momentum for $\tau \rightarrow \pi^\pm \pi^0 \rho \nu_\tau$ (also for 3-prong decays with $\rho \rightarrow \pi^+\pi^-$)

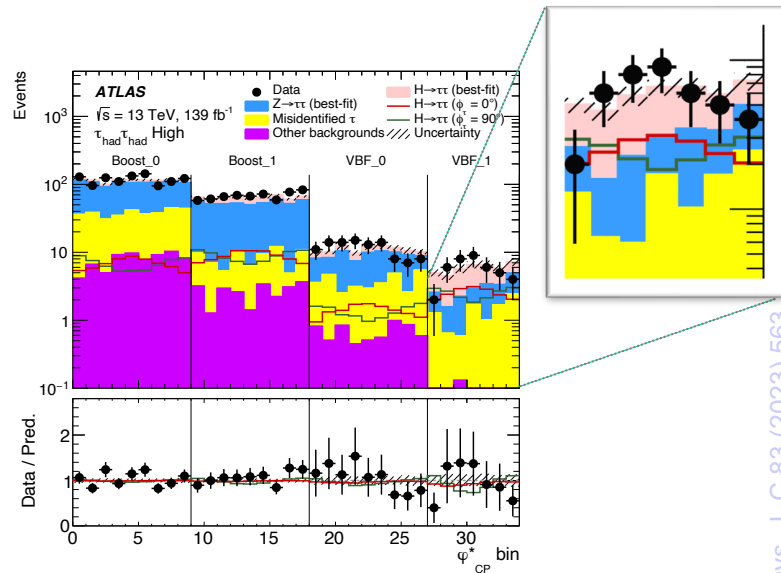

CP properties of Higgs- τ coupling with $H \rightarrow \tau\tau$

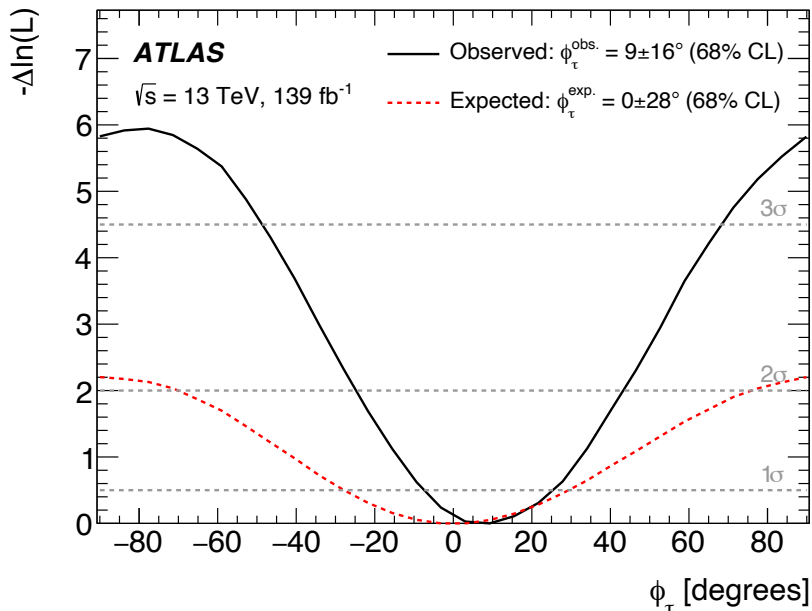
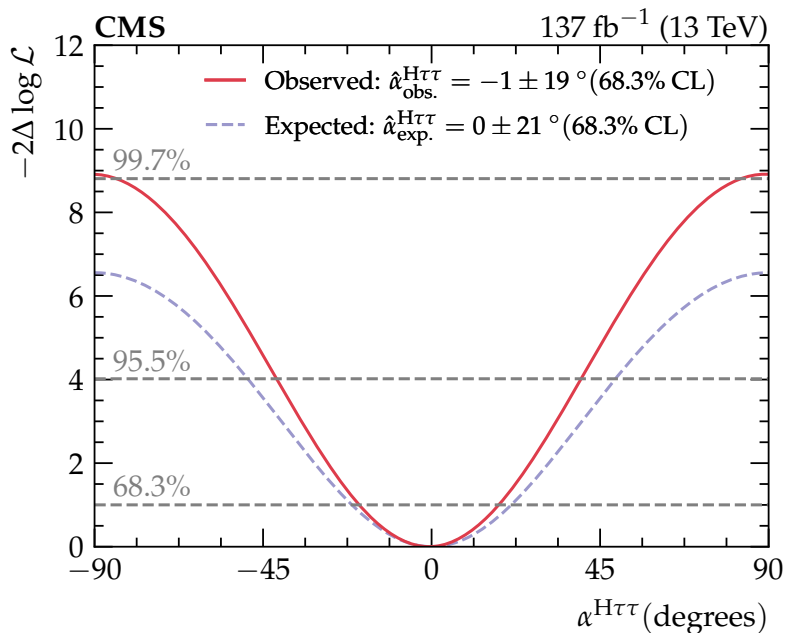

$$\phi_\tau = -1 \pm 19^\circ \text{ (21}^\circ \text{ exp)}$$

$$\alpha^{H\tau\tau}(\text{CMS}) = \phi_\tau(\text{ATLAS})$$

$$\phi_\tau = 9 \pm 16^\circ \text{ (28}^\circ \text{ exp)}$$

pure CP-odd coupling
excluded at **3 σ**

pure CP-odd coupling
excluded at **3.4 σ**

H → ττ decay CP

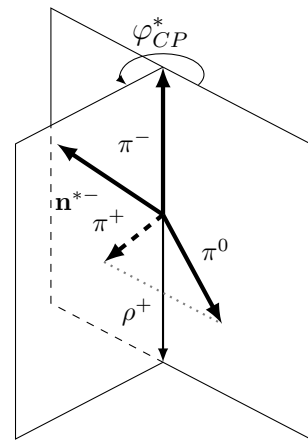
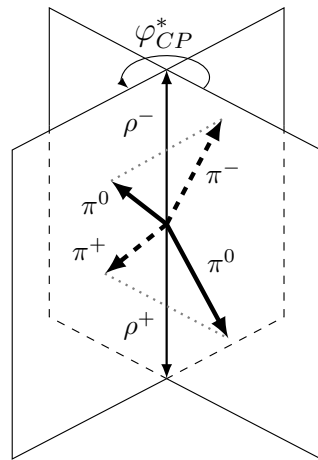
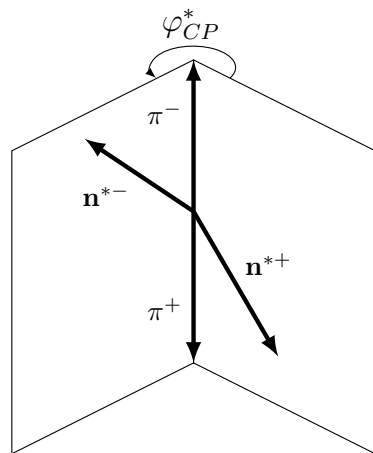
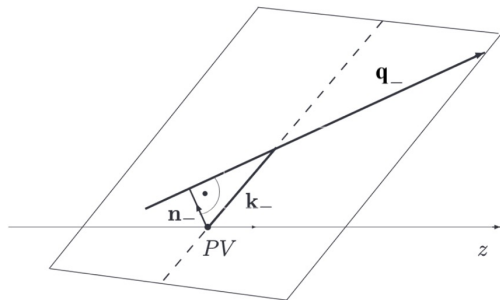

Impact parameter

directional distance of closest approach of charged particle's track to reconstructed PV of the event

4-vectors boosted to the rest frame of visible di-τ Zero Momentum Frame (e.g. two decay charged particles)

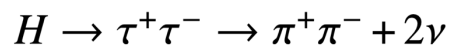

impact parameter

$$\varphi^* = \arccos(\hat{\mathbf{n}}_{\perp}^{*+} \cdot \hat{\mathbf{n}}_{\perp}^{*-})$$

$$O_{CP}^* = \hat{\mathbf{q}}^{*-} \cdot (\hat{\mathbf{n}}_{\perp}^{*+} \times \hat{\mathbf{n}}_{\perp}^{*-})$$

$$\varphi_{CP}^* = \begin{cases} \varphi^* & \text{if } O_{CP}^* \geq 0 \\ 360^\circ - \varphi^* & \text{if } O_{CP}^* < 0 \end{cases}$$

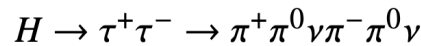

ρ decay plane

$$\varphi^* = \arccos(\hat{\mathbf{q}}_{\perp}^{*0+} \cdot \hat{\mathbf{q}}_{\perp}^{*0-})$$

$$O_{CP}^* = \hat{\mathbf{q}}^{*-} \cdot (\hat{\mathbf{q}}_{\perp}^{*0+} \times \hat{\mathbf{q}}_{\perp}^{*0-})$$

$$\varphi^{*'} = \begin{cases} \varphi^* & \text{if } O_{CP}^* \geq 0 \\ 360^\circ - \varphi^* & \text{if } O_{CP}^* < 0 \end{cases} \quad \varphi_{CP}^{*'} = \begin{cases} \varphi^{*'} & \text{if } y_+^{\rho}y_-^{\rho} \geq 0 \\ \varphi^{*'} + 180^\circ & \text{if } y_+^{\rho}y_-^{\rho} < 0 \end{cases} \quad y_{\pm}^{\rho} = \frac{E_{\pi^{\pm}} - E_{\pi^0}}{E_{\pi^{\pm}} + E_{\pi^0}}$$

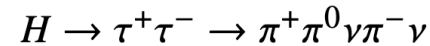

impact parameter + ρ decay plane

CP properties of Higgs-gluon coupling with ggF+VBF

Study ggF+2 jets events: jet kinematics sensitive to Hgg coupling CP properties

ATLAS: $\Delta\Phi_{jj}$ ggF+VBF $H \rightarrow WW^*$

CMS: $\Delta\Phi_{jj}$ or MELA discriminant ggF+VBF $H \rightarrow \tau\tau$

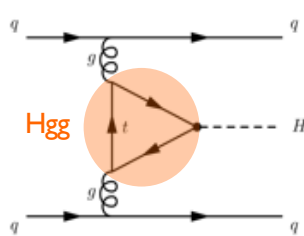

arXiv:2109.13808

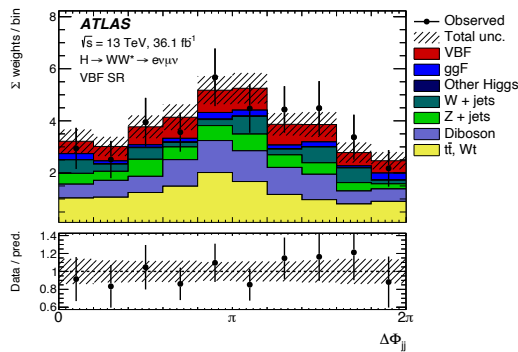
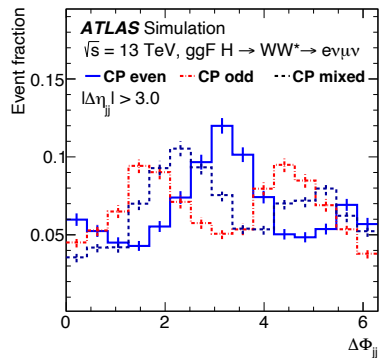

arXiv:2205.05120

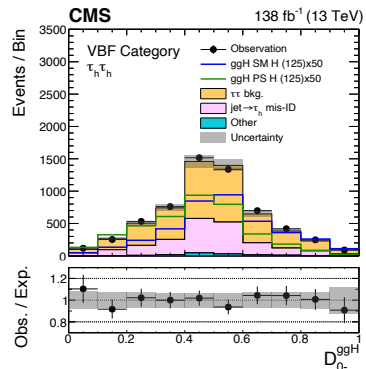

$$\mathcal{D}_{2jet}^{VBF} = \frac{\mathcal{P}_{SM}^{ggH} + \mathcal{P}_{0-}^{ggH}}{\mathcal{P}_{SM}^{ggH} + \mathcal{P}_{0-}^{ggH} + \mathcal{P}_{SM}^{VBF}} \quad \text{ggF vs VBF}$$

$$\mathcal{D}_{CP}^{ggH} = \frac{\mathcal{P}_{SM-0-}^{ggH}}{\mathcal{P}_{SM}^{ggH} + \mathcal{P}_{0-}^{ggH}} \quad \begin{array}{l} \text{ggF CP-even vs} \\ \text{ggF CP-odd} \end{array}$$

$$\mathcal{D}_{0-}^{ggH} = \frac{\mathcal{P}_{SM}^{ggH}}{\mathcal{P}_{SM}^{ggH} + \mathcal{P}_{0-}^{ggH}} \quad \begin{array}{l} \text{CP-even CP-odd} \\ \text{interference} \end{array}$$

$H \rightarrow WW^*$

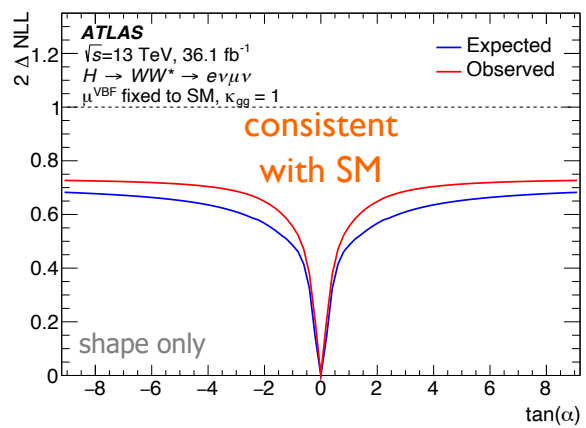

consistent with SM

α parameterizes CP-even/CP-odd mixture on Hgg coupling
shape only

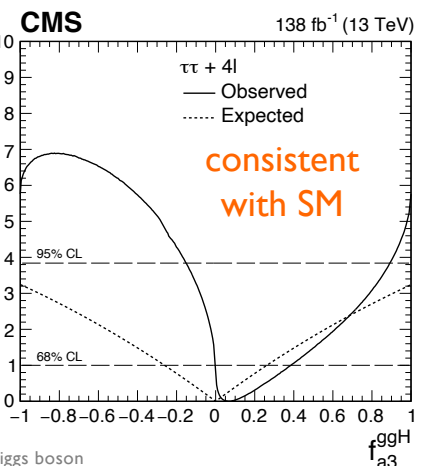

consistent with SM

$H \rightarrow \tau\tau$
(combined with $H \rightarrow 4l$)

f_{a3}^{ggH} parameterizes fraction of CP-odd BSM point-like Hgg coupling

CP properties of HVV coupling (mult. prod. + $H \rightarrow 4l$)

HVV couplings parameterized by **tensor structures in scattering amplitude**

$$\mathcal{A}(\text{HVV}) \sim \left[a_1^{\text{VV}} + \frac{\kappa_1^{\text{VV}} q_1^2 + \kappa_2^{\text{VV}} q_2^2}{(\Lambda_1^{\text{VV}})^2} \right] m_{\text{V}1}^2 \epsilon_{\text{V}1}^* \epsilon_{\text{V}2}^* + a_2^{\text{VV}} f_{\mu\nu}^{*(1)} f^{*(2)\mu\nu} + a_3^{\text{VV}} f_{\mu\nu}^{*(1)} \tilde{f}^{*(2)\mu\nu}.$$

$$f_{a3} = \frac{|a_3|^2 \sigma_3}{|a_1|^2 \sigma_1 + |a_2|^2 \sigma_2 + |a_3|^2 \sigma_3 + |\kappa_1|^2 \sigma_{\Lambda 1} + |\kappa_1^{Z\gamma}|^2 \sigma_{\Lambda 1}^{Z\gamma}} \text{sgn} \left(\frac{a_3}{a_1} \right)$$

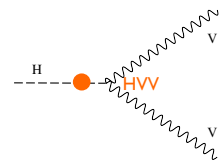
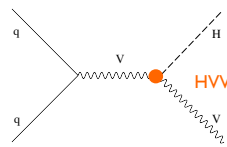
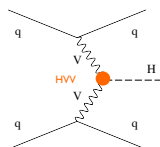

Multiple analyses constraining HVV couplings with ggH , VBF, VH, ttH , tH production and $H \rightarrow \tau\tau$, $H \rightarrow 4l$, $H \rightarrow \gamma\gamma$ decay

f_{a3} parameterizes fractional contribution of **CP-odd HZZ** coupling

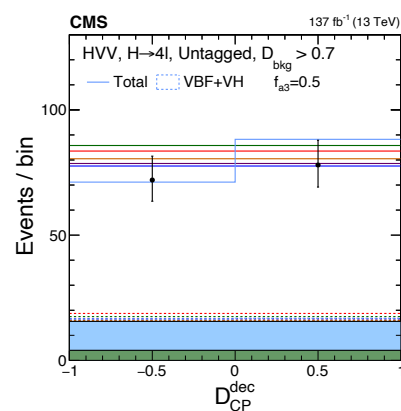
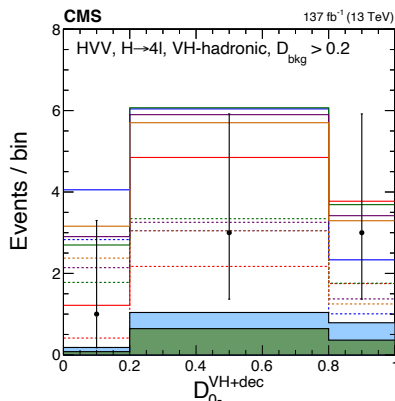
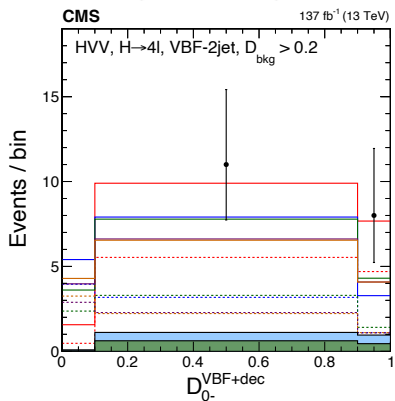
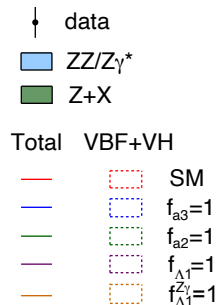

CP properties of HVV coupling (mult. prod. + $H \rightarrow 4l$; offshell)

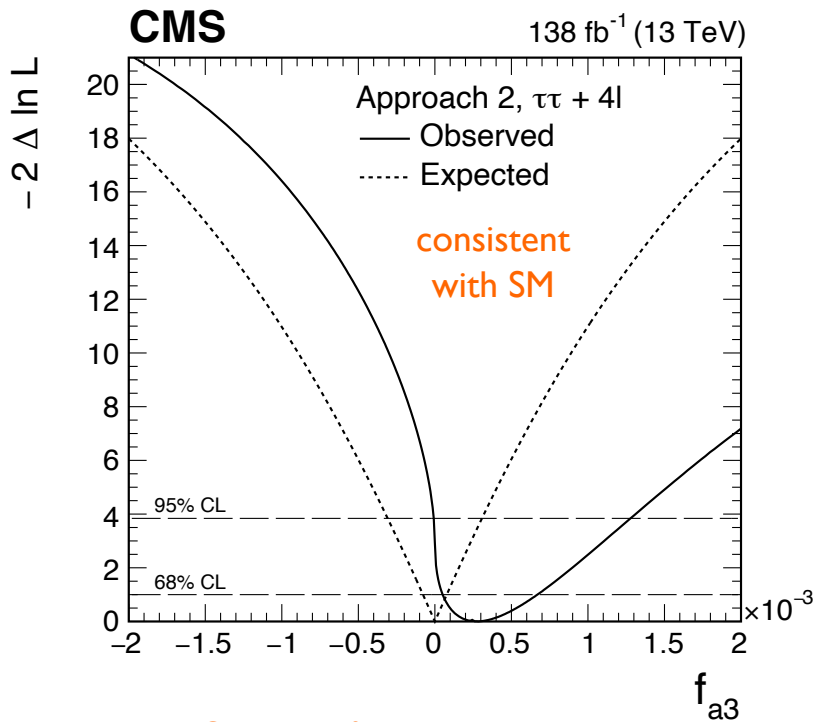

Constraint from combined analyses
Other anomalous HVV fixed to 0

$$f_{a3} = 0.20^{+0.26}_{-0.16} \times 10^{-3}$$

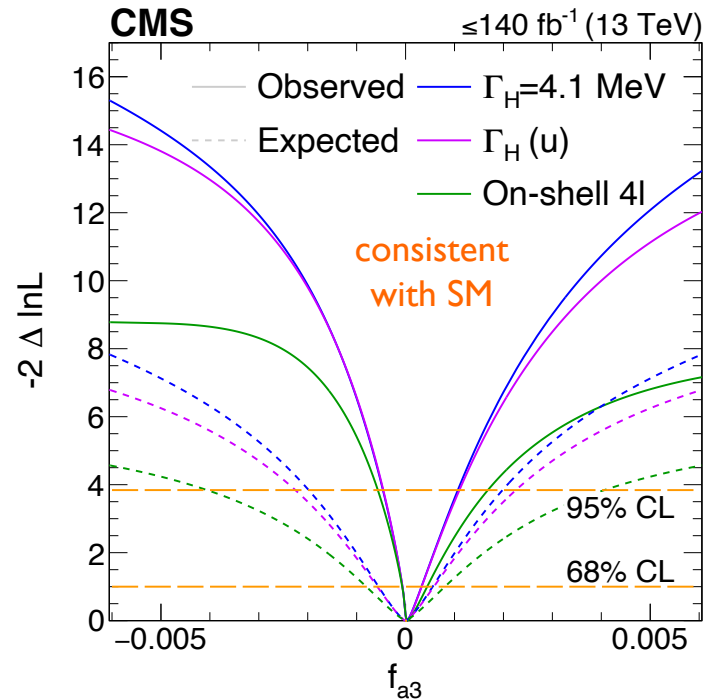

Constraints from $H \rightarrow 4l$ onshell + off-shell
Other anomalous couplings floated in fits

$$f_{a3} = 0.024^{+0.32}_{-0.064} \times 10^{-3}$$

CP properties of HVV coupling with VBF

SM Lagrangian augmented with CP-odd dim-6 operators involving Higgs and EW gauge fields in EFT formalism

$$|\mathcal{M}|^2 = |\mathcal{M}_{SM}|^2 + \tilde{d} \cdot 2\text{Re}(\mathcal{M}_{SM}^* \mathcal{M}_{CP\text{-odd}}) + \tilde{d}^2 \cdot |\mathcal{M}_{CP\text{-odd}}|^2$$

Approach pursued with various decay modes, here most recent ATLAS $H \rightarrow \gamma\gamma$, then combined with $36 \text{ fb}^{-1} H \rightarrow \tau\tau$

$$c_{H\tilde{W}} = c_{H\tilde{B}}$$

$$c_{HW\tilde{B}} = 0$$

$$\tilde{d} = \frac{\nu^2}{\Lambda^2} c_{H\tilde{W}}$$

$$OO = \frac{2\text{Re}(\mathcal{M}_{SM}^* \mathcal{M}_{CP\text{-odd}})}{|\mathcal{M}_{SM}|^2}$$

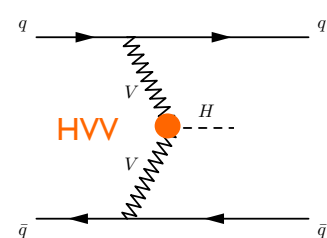

2 dedicated BDT's (VBF vs ggF, VBF vs $\gamma\gamma$)

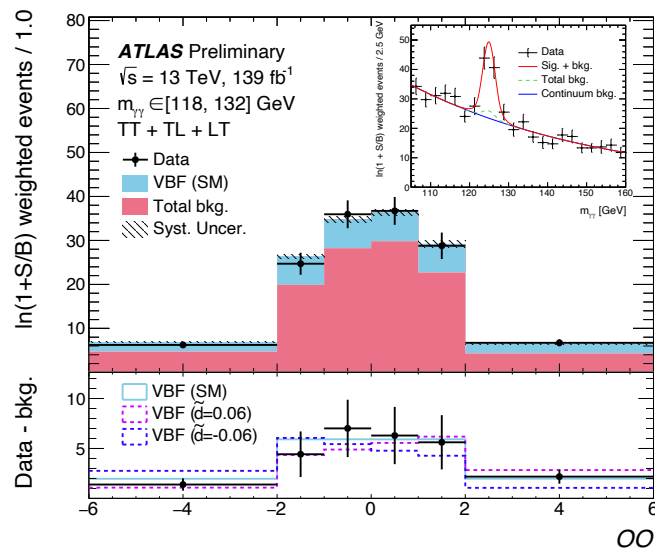
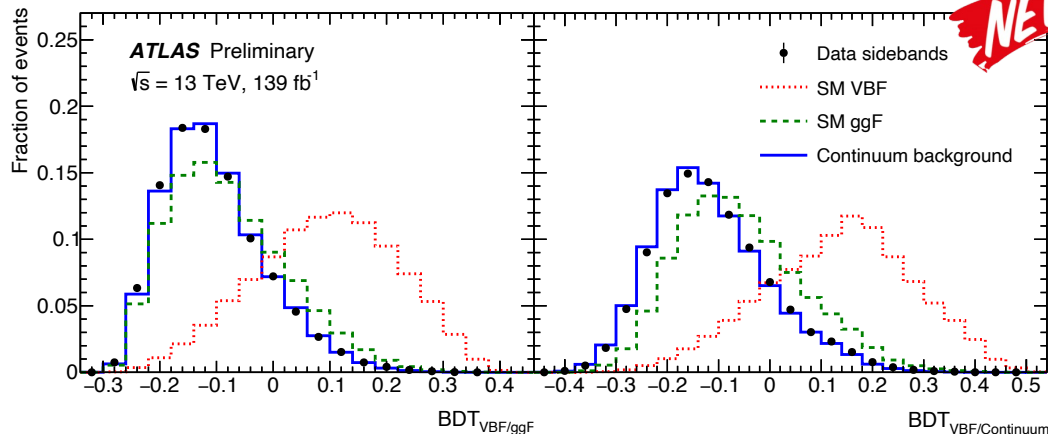

CP properties of HVV coupling with VBF

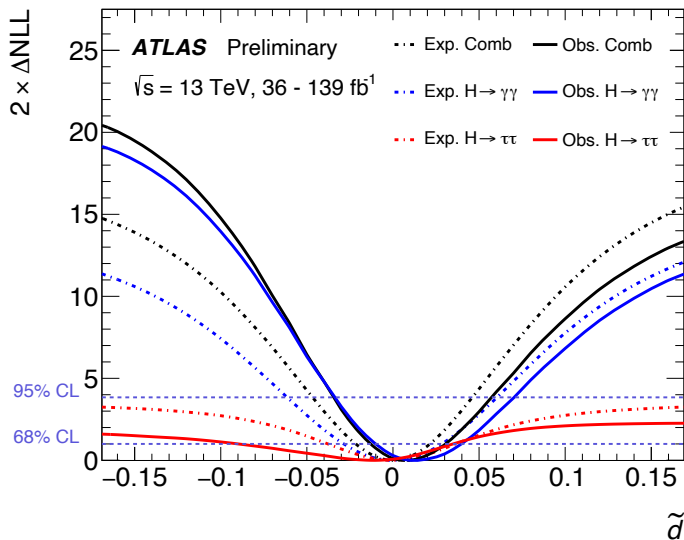
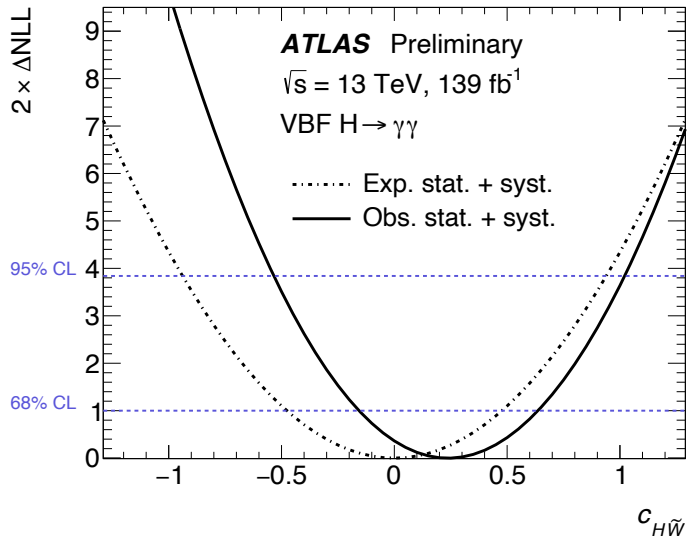

$$\tilde{d} = \frac{\nu^2}{\Lambda^2} c_{H\tilde{W}}$$

	68% (exp.)	95% (exp.)	68% (obs.)	95% (obs.)
\tilde{d} (inter. only)	[-0.027, 0.027]	[-0.055, 0.055]	[-0.011, 0.036]	[-0.032, 0.059]
\tilde{d} (inter.+quad.)	[-0.028, 0.028]	[-0.061, 0.060]	[-0.010, 0.040]	[-0.034, 0.071]
\tilde{d} from $H \rightarrow \tau\tau$	[-0.038, 0.036]	-	[-0.090, 0.035]	-
Combined \tilde{d}	[-0.022, 0.021]	[-0.046, 0.045]	[-0.012, 0.030]	[-0.034, 0.057]
$c_{H\tilde{W}}$ (inter. only)	[-0.48, 0.48]	[-0.94, 0.94]	[-0.16, 0.64]	[-0.53, 1.02]
$c_{H\tilde{W}}$ (inter.+quad.)	[-0.48, 0.48]	[-0.95, 0.95]	[-0.15, 0.67]	[-0.55, 1.07]

most stringent constraints on CP-properties of HVV coupling to date

Other information about the Higgs width?

- Part of Higgs width could be due to decays to undetectable particles ($H \rightarrow \text{invisible}$)
 - ✓ Limits from direct searches in $H \rightarrow \text{invisible}$, explicitly requiring MET in the event

[ATLAS-CONF-2020-052](#)

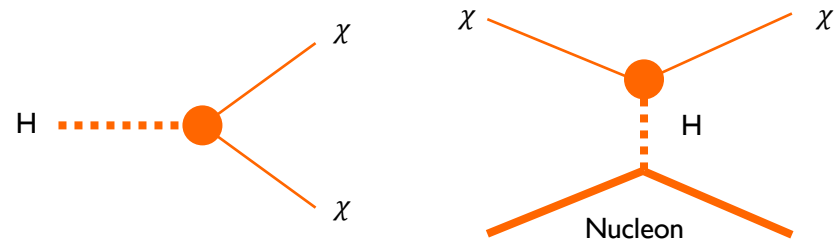
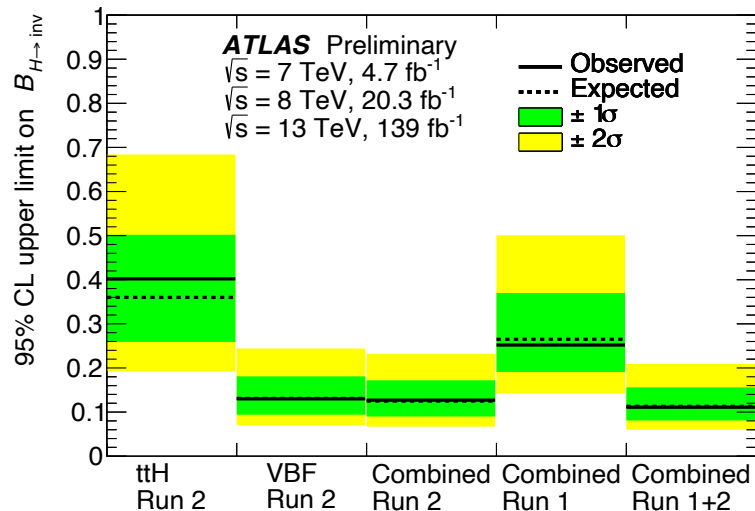

Limits on $BR(H \rightarrow \text{inv})$ can be recast in term of limit on Dark Matter production

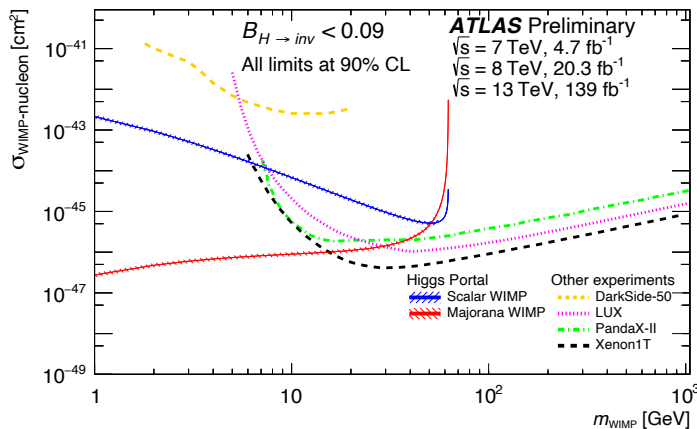

ATLAS: $BR(H \rightarrow \text{inv}) < 0.11$ (exp. 0.11) @ 95% CL

CMS: $BR(H \rightarrow \text{inv}) < 0.17$ (exp. 0.11) @ 95% CL

[CMS-PAS-HIG-20-003](#)

STXS at work: $H \rightarrow ZZ^*$

Eur. Phys. J. C 81 (2021) 488

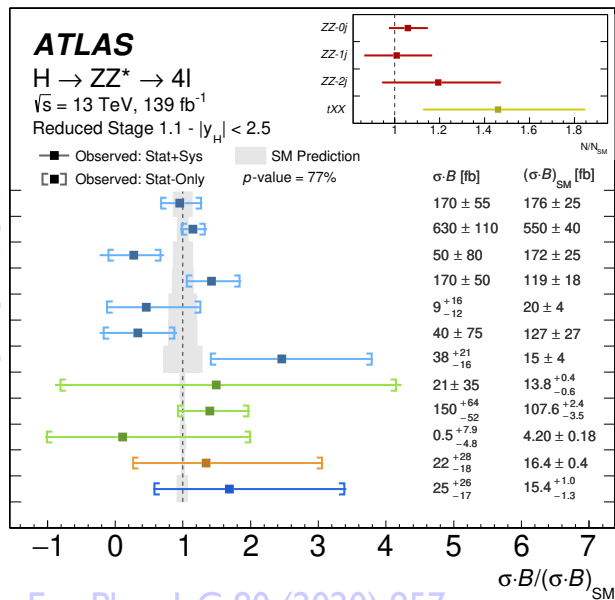
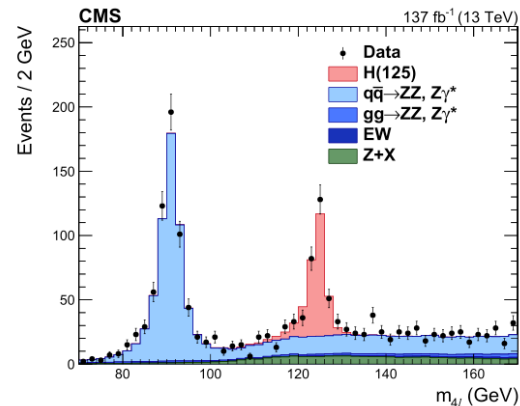
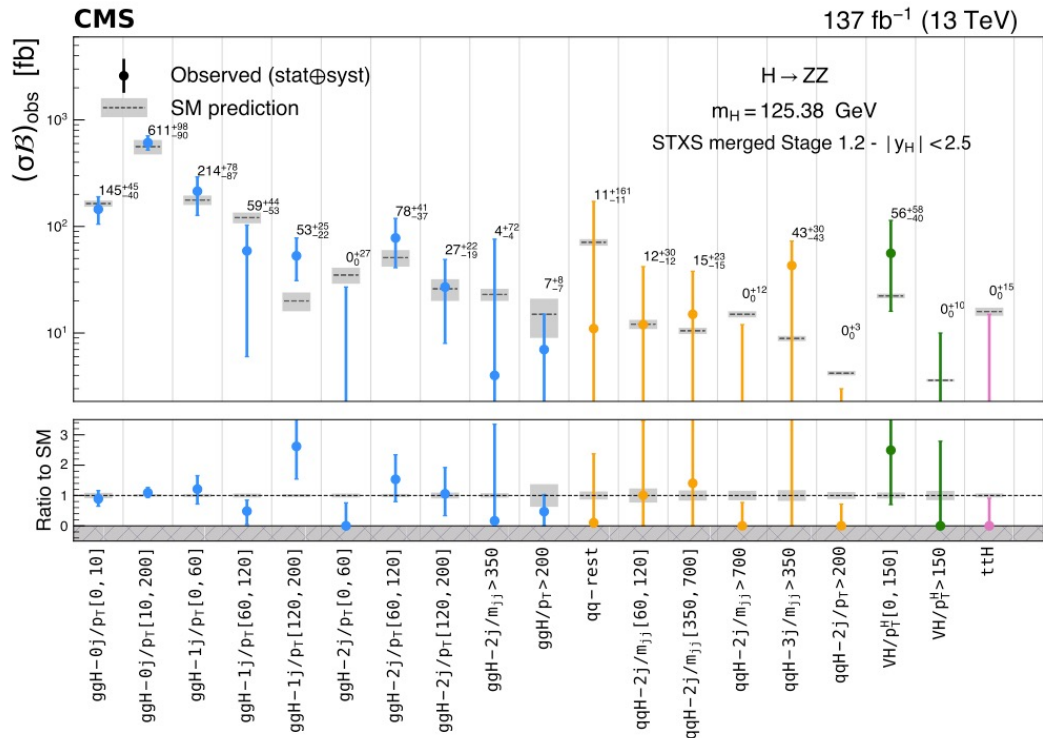

Eur. Phys. J. C 80 (2020) 957

STXS at work: $H \rightarrow WW^*$

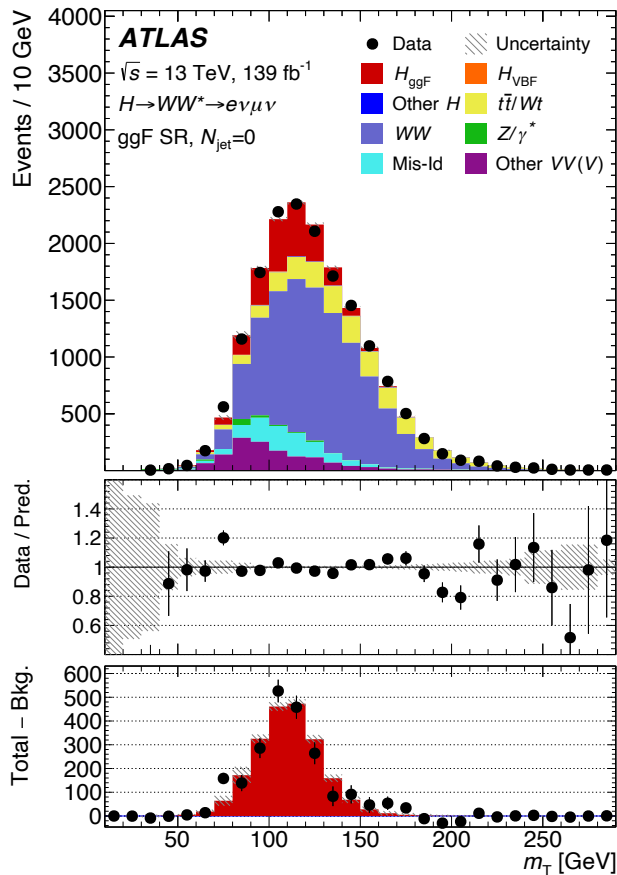

- Precision measurements have become a possibility also for those channels where reconstructing the final state is not possible, e.g. $H \rightarrow WW^*$ (neutrinos, missing transverse energy)!

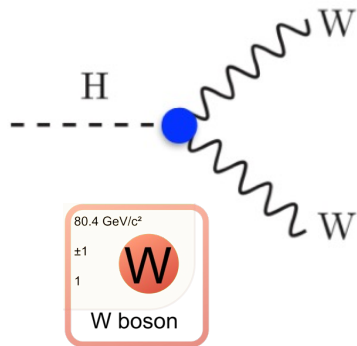
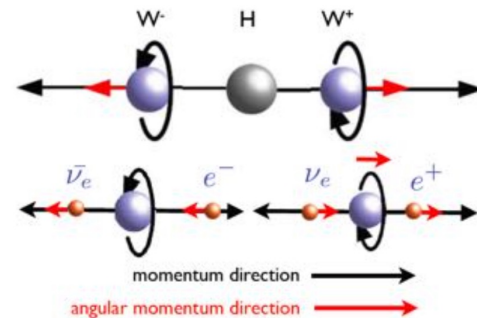

- $ggH-0j, p_T^H < 200 \text{ GeV}$
- $ggH-1j, p_T^H < 60 \text{ GeV}$
- $ggH-1j, 60 \leq p_T^H < 120 \text{ GeV}$
- $ggH-1j, 120 \leq p_T^H < 200 \text{ GeV}$
- $ggH-2j, p_T^H < 200 \text{ GeV}$
- $ggH, p_T^H \geq 200 \text{ GeV}$
- EW $qqH-2j, 350 \leq m_{ij} < 700 \text{ GeV}, p_T^H < 200 \text{ GeV}$
- EW $qqH-2j, 700 \leq m_{ij} < 1000 \text{ GeV}, p_T^H < 200 \text{ GeV}$
- EW $qqH-2j, 1000 \leq m_{ij} < 1500 \text{ GeV}, p_T^H < 200 \text{ GeV}$
- EW $qqH-2j, m_{ij} \geq 1500 \text{ GeV}, p_T^H < 200 \text{ GeV}$
- EW $qqH-2j, m_{ij} \geq 350 \text{ GeV}, p_T^H \geq 200 \text{ GeV}$

arXiv:2207.0033

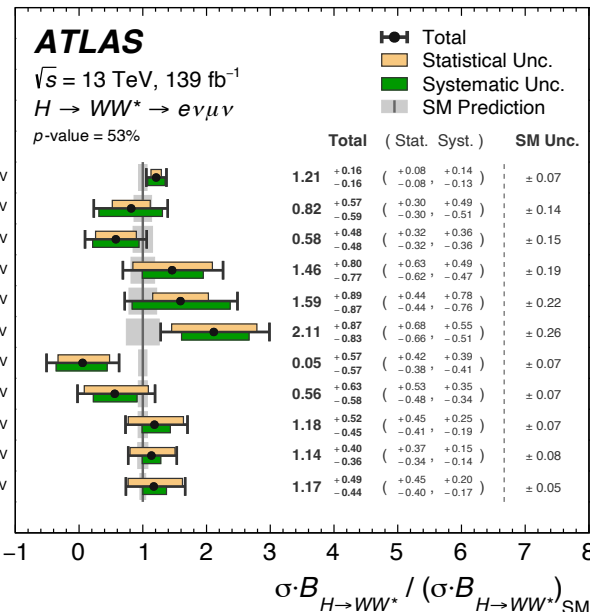

H \rightarrow $\gamma\gamma$ and H \rightarrow ZZ*: differential and fiducial cross-sections

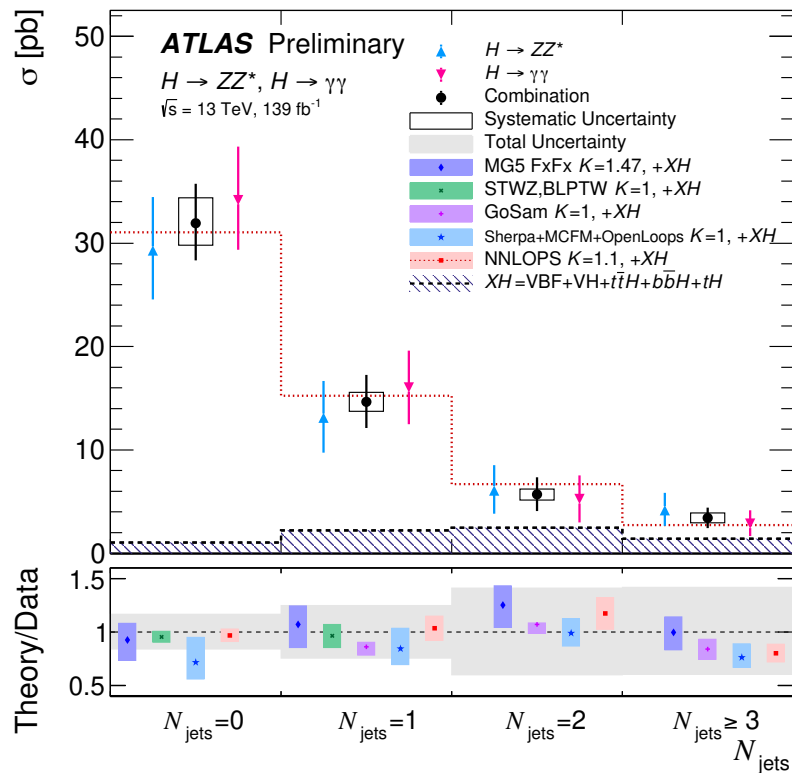
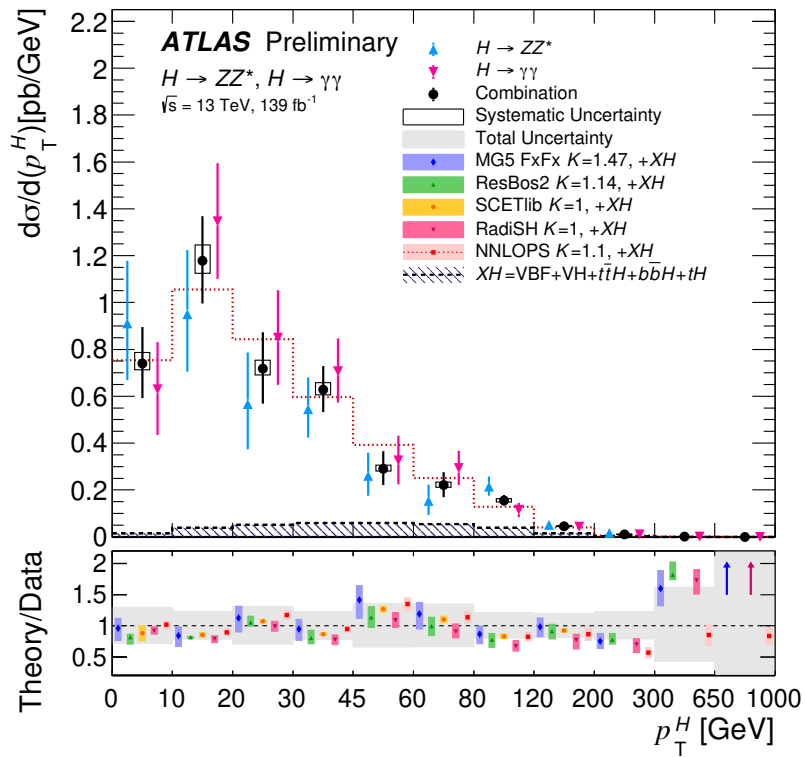

[ATLAS-CONF-2022-002](#)

$H \rightarrow \gamma\gamma$ and $H \rightarrow ZZ^*$: inclusive cross-sections

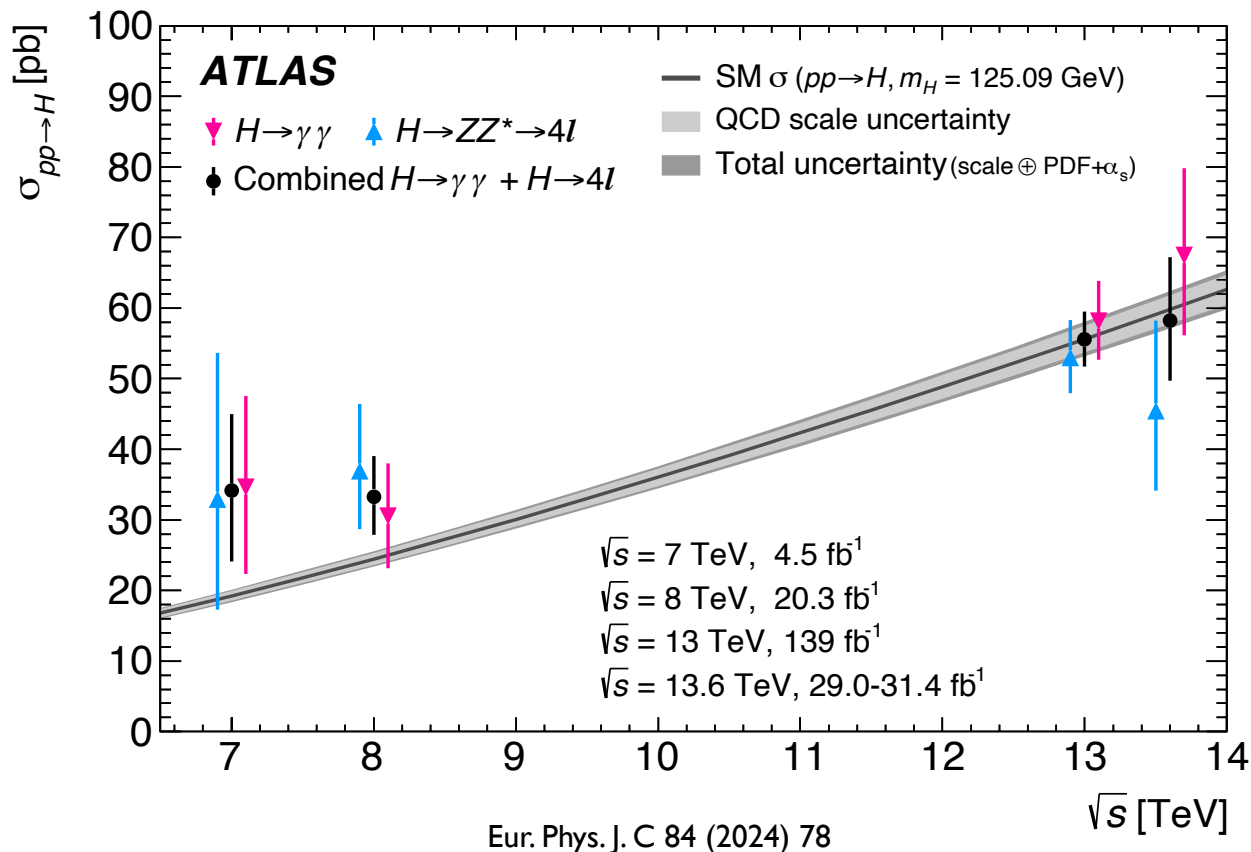

Reaching the highest p_T^H with $H \rightarrow bb$

arXiv:2111.08340

JHEP12(2020)085

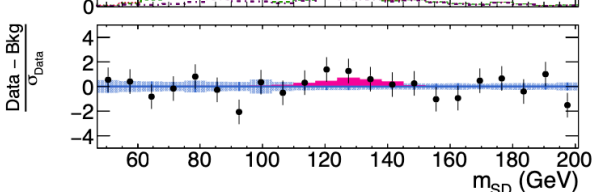
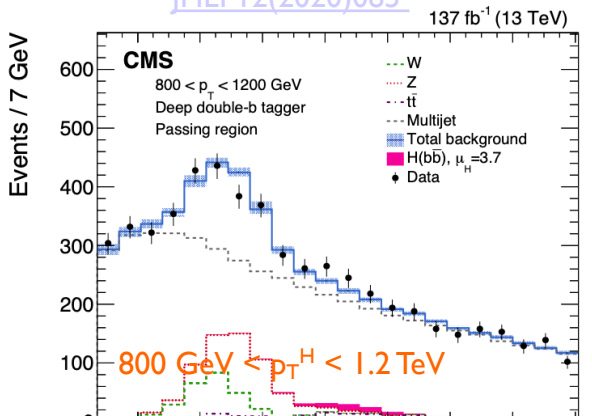
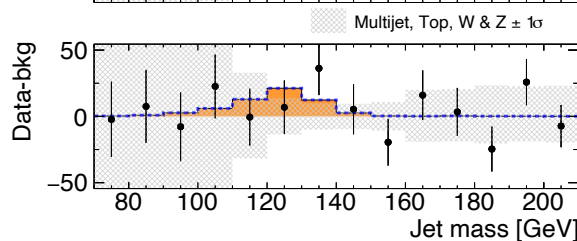
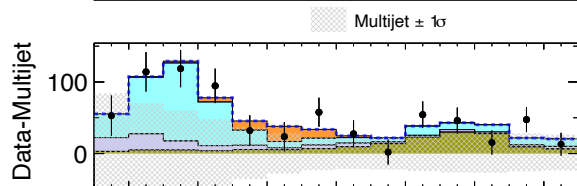
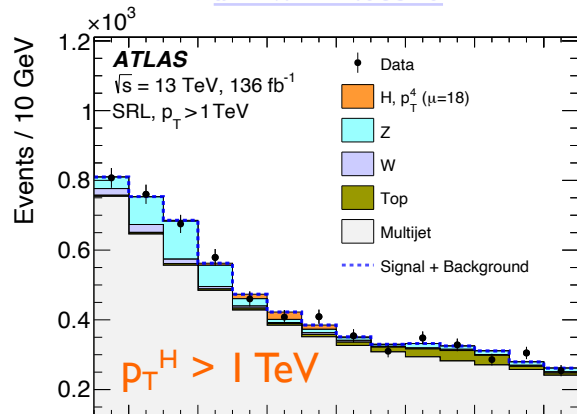

- Jets substructure with 1 or 2 b-tags
- Fiducial cross-section (mostly ggF)
- Can be recasted as STXS
- Highest p_T^H most sensitive to BSM effects

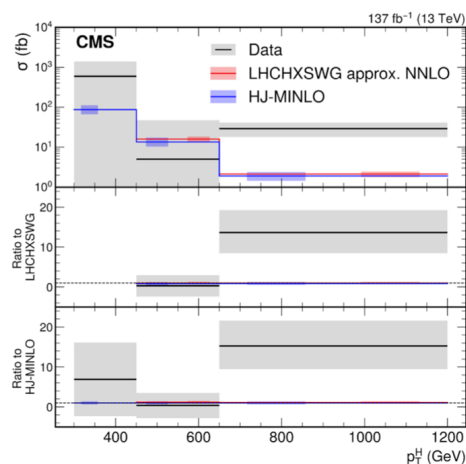
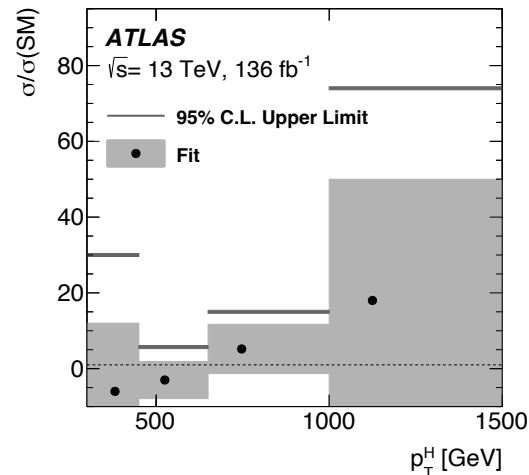

Other rare Higgs decays within reach?

evd. = evidence

Analysis	Final states	13 TeV \mathcal{L} [fb $^{-1}$]	BR (SM)	$\sigma_H \times \text{BR(H decays)}$	ATLAS/CMS references
$c\bar{c}$		139, 35.9	2.9%	$26 \times \text{SM}, 70 \times \text{SM}$	ATLAS-CONF-2021-021, JHEP 03 (2020) 131
invisible		139, 35.9	$\sim 10^{-3}$		ATLAS-CONF-2020-052, PLB 793 (2019) 520
$Z\gamma$	$ee/\mu\mu+\gamma$	139, 35.9	$\sim 10^{-3}$	evd. $\mu = 1.5, 3.9 \times \text{SM}$	arXiv:2103.10322 (PLB 2021), JHEP 11 (2018) 152
$\mu^+\mu^-$		139, 137	$\sim 10^{-4}$	$2.2 \times \text{SM}, \text{evd. } \mu = 1.19$	PLB 812 (2021) 135980, JHEP 01 (2021) 148
BR(H decays)					
$\rho\gamma$	$\pi^+\pi^-\gamma$	35.6	$\sim 10^{-5}$	8.8×10^{-4}	JHEP 07 (2018) 127
$\phi\gamma$	$K^+K^-\gamma$		$\sim 10^{-6}$	4.8×10^{-4}	
$Z\rho$	$ee/\mu\mu + \pi^+\pi^-$	137	$\sim 10^{-5}$	$(1.04-1.31) \times 10^{-2}$	JHEP 11 (2020) 039
$Z\phi$	$ee/\mu\mu + K^+K^-$	137	$\sim 10^{-6}$	$(3-4) \times 10^{-3}$	
$Z\eta_c$	$ee/\mu\mu + \text{had}$	139	$\sim 10^{-5}$	$(\sigma \times \text{BR} = 110 \text{ pb})$	PRL 125 (2020) 221802
ZJ/ψ			$\sim 10^{-6}$	$(\sigma \times \text{BR} = 100 \text{ pb})$	
$J/\psi \gamma$	} $\mu^+\mu^-\gamma$	36.1, 35.9	$\sim 10^{-6}$	$3.5 \times 10^{-4}, 7.6 \times 10^{-4}$	PLB 786 (2018) 134, EPJ C 79 (2019) 94
$\psi(2S)\gamma$		36.1	$\sim 10^{-6}$	2.0×10^{-3}	PLB 786 (2018) 134
$\Upsilon(nS)\gamma$ (n=1,2,3)		36.1	$\sim 10^{-9}$	$(4.9, 5.9, 5.7) \times 10^{-4}$	
$\Upsilon\Upsilon$	} 4μ		$\sim 10^{-9}$	1.4×10^{-3}	
$J/\psi J/\psi$		37.5	$\sim 10^{-10}$	1.8×10^{-3}	PLB 797 (2019) 134811
e^+e^-		139	$\sim 10^{-9}-10^{-10}$	3.6×10^{-4}	PLB 801 (2020) 135148

Imma Riu @ LHCP 2021

Other rare Higgs decays within reach?

- $SU(2)_L$ symmetry relates the HWW , HZZ , $H\gamma\gamma$ and $HZ\gamma$ interactions
 - ✓ If New Physics respects $SU(2)_L$, effect correlated in all four channels
 - ✓ Important to observed and measure also $H \rightarrow Z\gamma$

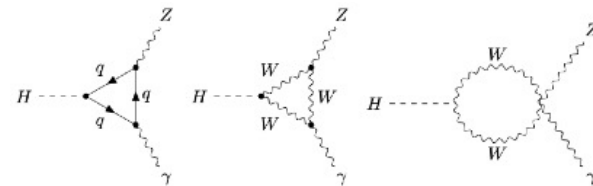

[Phys. Rev. Lett. 132 \(2024\) 021803](#)

JHEP 05 (2023) 233

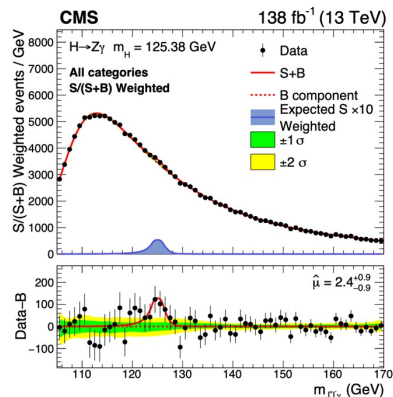

$\mu = 2.4 \pm 0.9$
Significance: 2.7σ
(1.2 expected)

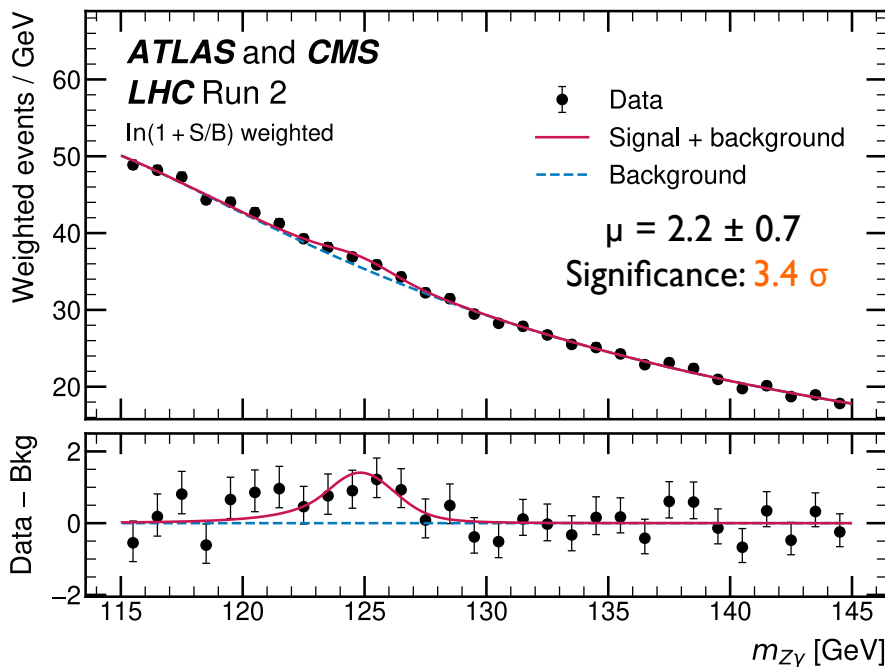

[Phys. Lett. B 809 \(2020\) 135754](#)

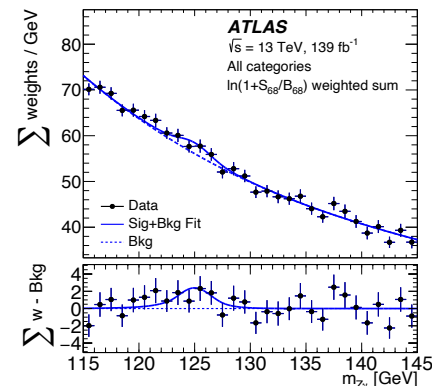

$\mu = 2.0 \pm 0.9$
Significance: 2.2σ
(1.2 expected)

How well should we know the Higgs couplings?

SMALL CORRECTIONS EXPECTED IN MANY BSM MODELS

If new physics is at 1 TeV:

	$\delta\kappa_V$	$\delta\kappa_b$	$\delta\kappa_\gamma$
Singlet	<6%	<6%	<6%
2HDM (large $\tan\beta$)	~1%	~10%	~1%
MSSM	~.001%	~1.6%	~-0.4%
Composite	~-3%	~-(3-9)%	~-9%
Top Partner	~-2%	~-2%	~1%

Patterns of deviations can pinpoint specific BSM physics

- Generically new physics effects on couplings $\sim \frac{v^2}{M^2} \sim \mathcal{O}(6\%)$ for $M=1$ TeV
- Only now are we approaching sensitivity where we expect deviations

More tools at hand! Constraining κ_λ with single-Higgs

- Single Higgs boson productions and decays as well as kinematics sensitive to the self-coupling through EW corrections

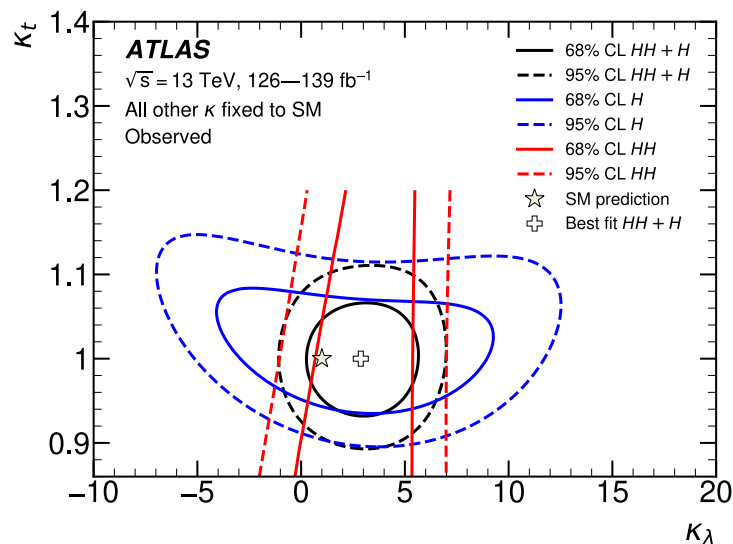
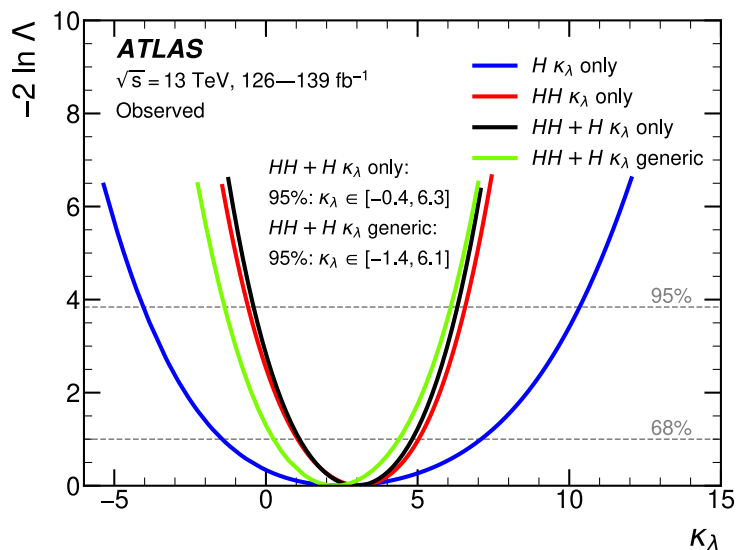
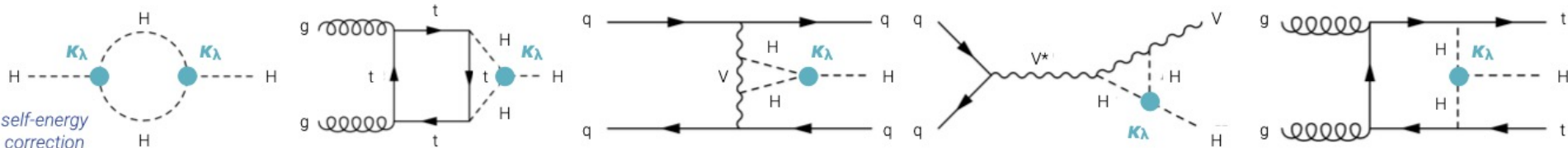

arXiv:2211.01216

Direct $H \rightarrow cc$ search is not the only tool...

- Charm quark contributes to ggF loop, modification to Higgs-charm coupling can alter $p_{T,H}$
- Analogous effect on quark-initiated production of the Higgs boson
- Shape of differential $p_{T,H}$ cross-section can be interpreted in term of Higgs-charm coupling

[arXiv:1606.09253](https://arxiv.org/abs/1606.09253)

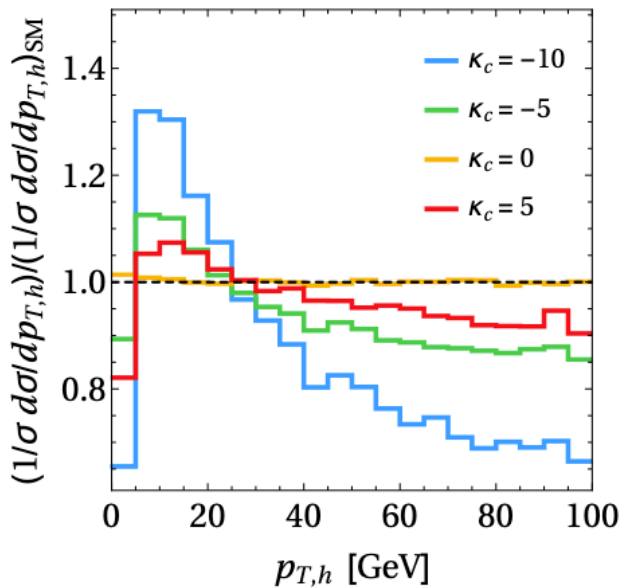

[ATLAS-CONF-2022-002](https://arxiv.org/abs/2202.00022)

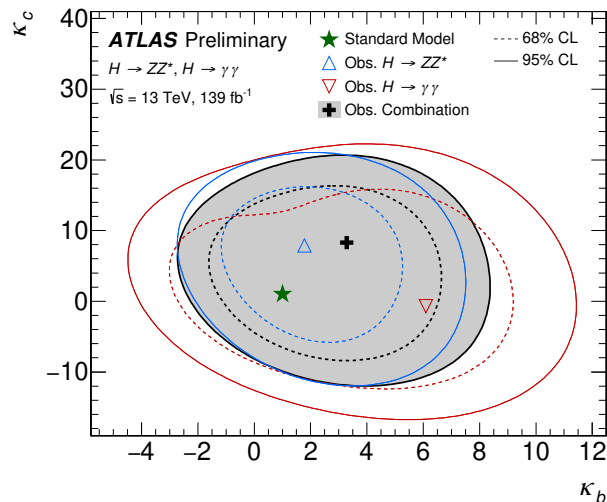
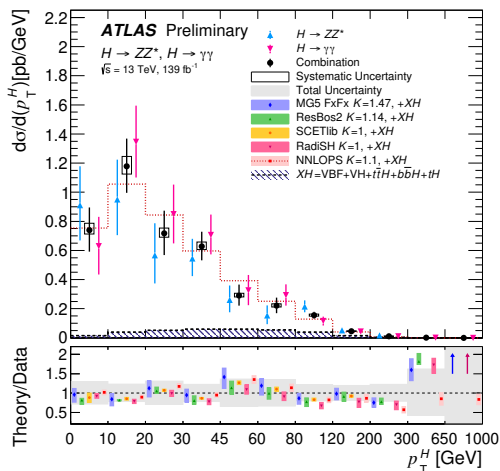

Channel	Parameter best-fit	Observed 95% confidence interval	Expected 95% confidence interval
Combined	$\kappa_b = 3.3^{+2.4}_{-4.1}$	[-2.1, 7.4]	[-2.2, 7.4]
	$\kappa_c = 8.3^{+5.5}_{-13.8}$	[-10.1, 18.3]	[-10.3, 16.6]

Higgs boson

Why is the electroweak interaction so much stronger than gravity?

- Are there new particles close to the mass of the Higgs boson?
- Is the Higgs boson elementary or made of other particles?
- Are there anomalies in the interactions of the Higgs boson with the W and Z bosons?

Why is there more matter than antimatter in the Universe?

- Are there charge-parity violating Higgs decays?
- Are there anomalies in the Higgs self-coupling that would imply a strong first-order early-Universe electroweak phase transition?
- Are there multiple Higgs sectors?

What is dark matter?

- Can the Higgs boson provide a portal to dark matter or a dark sector?
- Is the Higgs lifetime consistent with the Standard Model?
- Are there new decay modes of the Higgs boson?

What is the origin of the vast range of quark and lepton masses in the Standard Model?

- Are there modified interactions to the Higgs boson and known particles?
- Does the Higgs boson decay into pairs of quarks or leptons with distinct flavours (for example, $H \rightarrow \mu^+ \tau^-$)?

What is the origin of the early Universe inflation?

- Any imprint in cosmological observations?

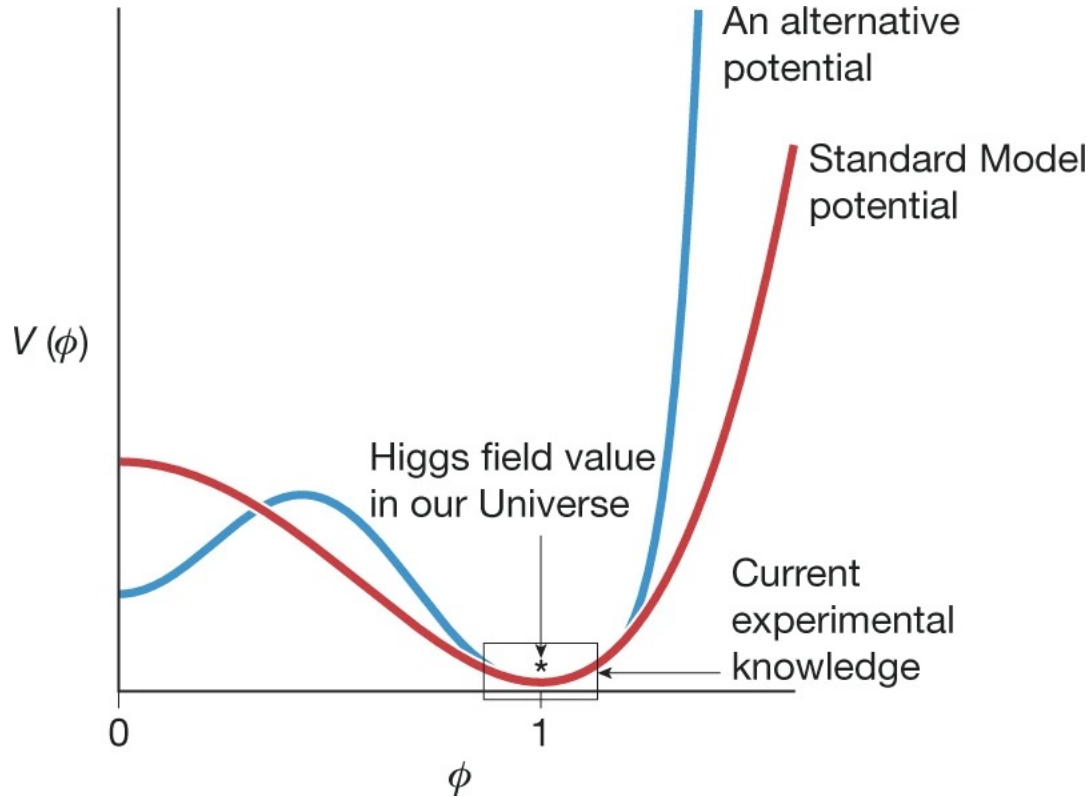

Is it the Standard Model Higgs potential?

- How the Higgs potential is realized in Nature can provide important answers to many open points in our understanding of Nature...
 - ✓ e.g. BSM scenarios of Higgs sector, electroweak phase transition in the SM, baryogenesis...

Different models predicts different potential shape

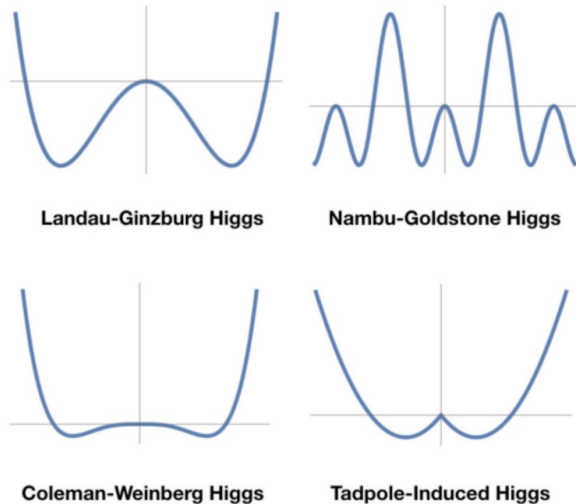

[Phys. Rev. D 101, 075023 \(2020\)](#)

Evolution of Higgs potential could explain matter/antimatter asymmetry via electroweak baryogenesis

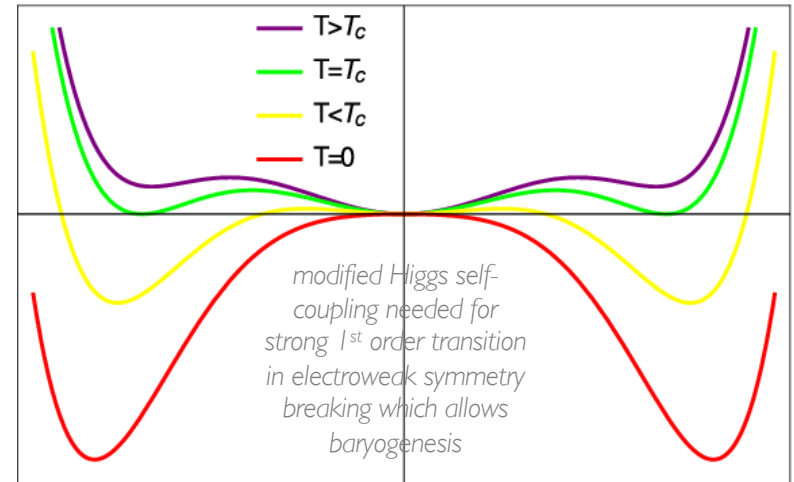

[arXiv:1511.03969](#)

The FCC-ee physics program at a glance

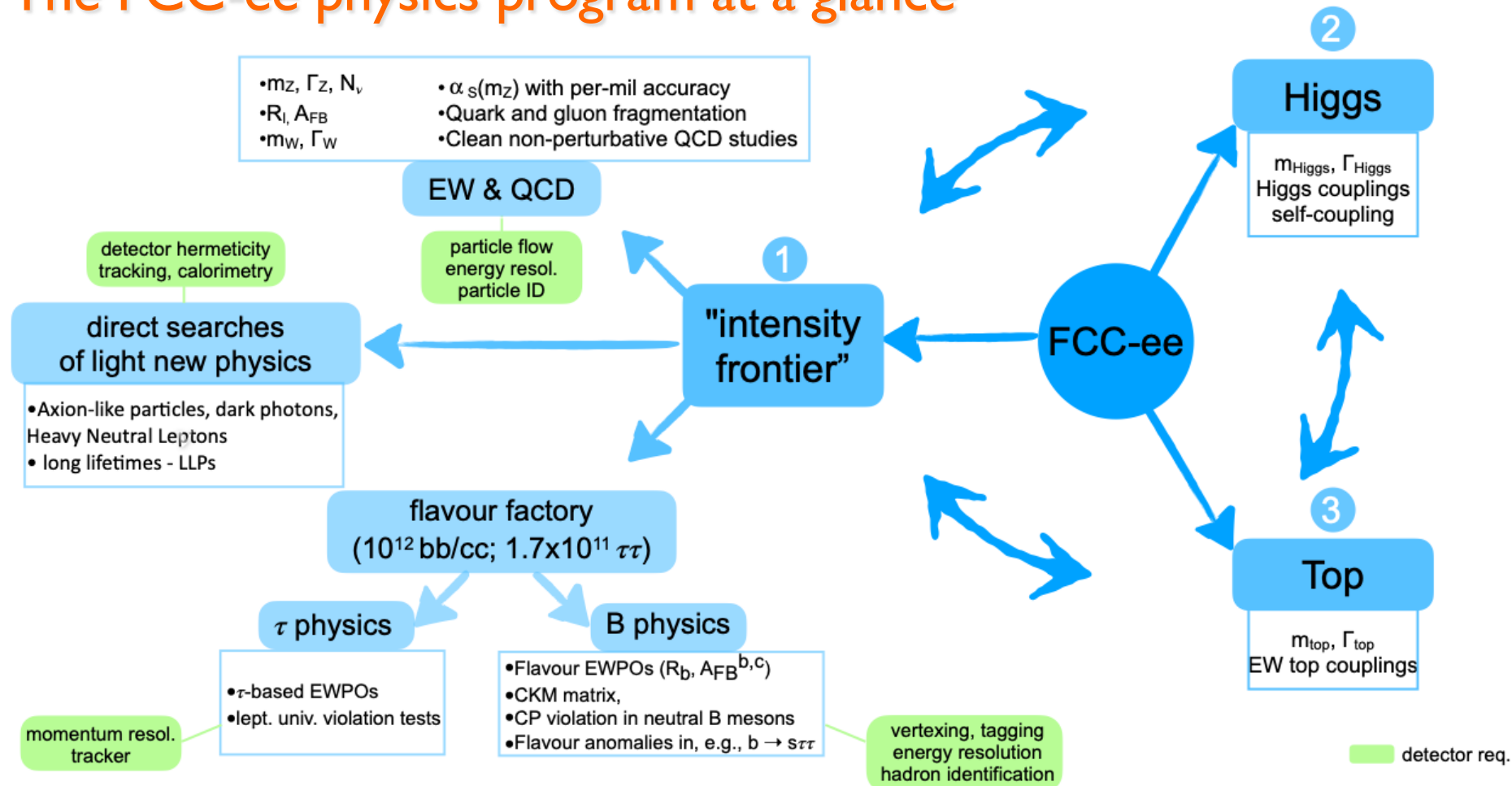

Where FCC excels...

Physics ↓ \ √s →	e ⁺ e ⁻ collisions						pp collisions			Leading Physics Questions
	m _Z	2m _W	HZ max. 240-250 GeV	2m _{top} 340-380 GeV	500 GeV	1.5 TeV	3 TeV	28 TeV 37 TeV 48 TeV	100 TeV	
Precision EW (Z, W, top)	Transverse polarization	Transverse polarization		m _W , α _S						Existence of more SM-Interacting particles
QCD (α _S) QED (α _{QED})	5×10 ¹² Z	3×10 ⁸ W	10 ⁵ H→gg							Fundamental constants and tests of QED/QCD
Model-independent Higgs couplings		ee → H √s = m _H	1.2×10 ⁶ HZ and 75k WW→H at two energies						<1% precision (*)	Test Higgs nature
Higgs rare decays									<1% precision (*)	Portal to new physics
Higgs invisible decays									10 ⁻⁴ BR sensitivity	Portal to dark matter
Higgs self-coupling			3 to 5σ from loop corrections to Higgs cross sections						5% (HH prod) (*)	Key to EWSB
Flavours (b, τ)	5×10 ¹² Z									Portal to new physics Test of symmetries
RH ν's, Feebly interacting particles	5×10 ¹² Z								10 ¹¹ W	Direct NP discovery At low couplings
Direct search at high scales					M _X <250GeV Small ΔM	M _X <750GeV Small ΔM	M _X <1.5TeV Small ΔM		Up to 40 TeV	Direct NP discovery At high mass
Precision EW at high energy							Y		W, Z	Indirect Sensitivity to Nearby new physics
Quark-gluon plasma Physics w/ injectors										QCD at origins

Green = Unique to FCC; Blue = Best with FCC; (*) = if FCC-hh is combined with FCC-ee; Pink = Best with other colliders

FCC-ee motivations

LEP data accumulated in first 3 mn. Then exciting & diverse programme with different priorities every few years.
(order of the different stages still subject to discussion/optimisation)

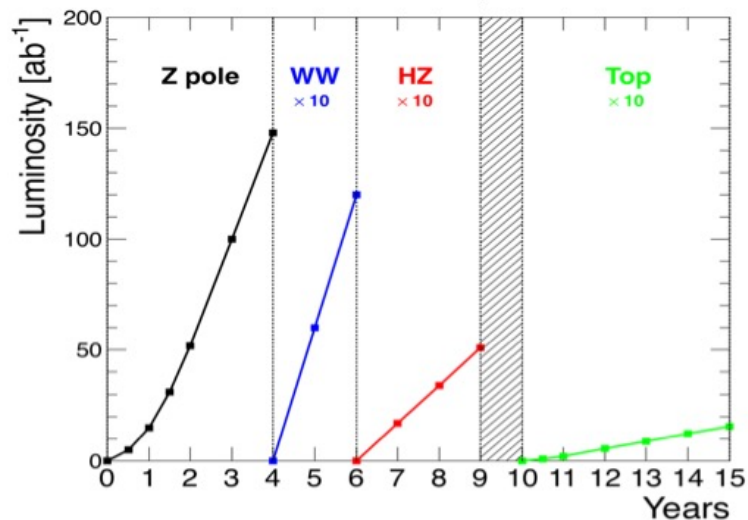

Phase	Run duration (years)	Center-of-mass Energies (GeV)	Integrated Luminosity (ab^{-1})
FCC-ee-Z	4	88-95	150
FCC-ee-W	2	158-162	12
FCC-ee-H	3	240	5
FCC-ee-tt	5	345-365	1.5

Superb statistics achieved in only 15 years

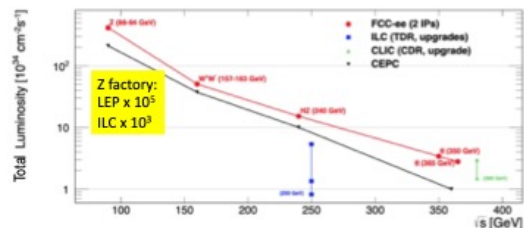

Event statistics (2IP)

Z peak	$E_{\text{cm}} : 91 \text{ GeV}$	4yrs	$5 \cdot 10^{12} \text{ e}+\text{e}^- \rightarrow \text{Z}$	LEP x 10^5	$< 100 \text{ keV}$
WW threshold	$E_{\text{cm}} \geq 161 \text{ GeV}$	2yrs	$> 10^8 \text{ e}+\text{e}^- \rightarrow \text{WW}$	LEP x $2 \cdot 10^3$	$< 300 \text{ keV}$
ZH maximum	$E_{\text{cm}} : 240 \text{ GeV}$	3yrs	$> 10^6 \text{ e}+\text{e}^- \rightarrow \text{ZH}$	Never done	1 MeV
s-channel H	$E_{\text{cm}} : m_H$	(3yrs?)	$O(5000) \text{ e}+\text{e}^- \rightarrow \text{H}$	Never done	$<< 1 \text{ MeV}$
tt	$E_{\text{cm}} : \geq 350 \text{ GeV}$	5yrs	$10^6 \text{ e}+\text{e}^- \rightarrow \text{tt}$	Never done	2 MeV

E_{CM} errors:

$< 100 \text{ keV}$
 $< 300 \text{ keV}$
1 MeV
 $<< 1 \text{ MeV}$
2 MeV

FCC-ee physics vs center-of-mass energies

— CDR baseline runs (4IPs)

— Additional opportunities

